

LEGEND

- ASPHALT PAVEMENT
- LANDSCAPE AREA
- CONCRETE SIDEWALK
- BUILDING AREA
- AMENDED SOILS AREA

PROJECT SUMMARY

AREA
 AREA: 55.56± ACRES
 APN: 499-010-074-000, (LOT 1) (25.88 AC)
 APN: 499-010-075-000, (LOT 2) (29.68 AC)

SPECIFIC PLAN
 SIERRA VISTA SPECIFIC PLAN
 PARCELS KT-41A AND KT-41B

LAND USE DESIGNATION
 COMMUNITY COMMERCIAL (CC)

ZONING
 GENERAL COMMERCIAL (GC)

PROPOSED USES
 COMMUNITY CARE FACILITY,
 LONG-TERM CARE FACILITY,
 AND MEDICAL SERVICES

DEVELOPER
 ERICKSON SENIOR LIVING, LLC
 701 MAIDEN CHOICE LANE
 BALTIMORE, MD 21228
 ATTN: STEVEN MONTGOMERY
 STEVEN.MONTGOMERY@ERICKSONSENIORLIVING.COM

PROPERTY OWNER
 KV SIERRA VISTA, LLC
 7700 COLLEGE TOWN DR, SUITE 101
 SACRAMENTO, CA 95826

ENGINEER
 KIMLEY-HORN AND ASSOCIATES
 555 CAPITOL MALL, SUITE 300
 SACRAMENTO, CA 95814
 ATTN: FAREED PITTALWALA
 FAREED.PITTALWALA@KIMLEY-HORN.COM

ARCHITECT
 LANTZ-BOGGIO
 5650 DTC PARKWAY, SUITE 200
 ENGLEWOOD, CO 80111
 ATTN: DAVID FIK
 DFIK@LANTZ-BOGGIO.COM

BUILDING SUMMARY

BUILDING	STORIES	SQUARE FEET	PARKING
RB 1.1	5	205,730	
CB 1.0	1	14,720	
COMMONS 1A	1	5,280	
RB 1.2	5	194,779	
COMMONS 1B	1	19,546	
RB 1.3	6	184,075	
RB 1.4	6	151,900	
RB 1.5	6	198,409	
SNF	1	27,262	1822
RB 2.1	5	182,482	
CB 2.0	1	19,077	
COMMONS 2A	1	3,100	
RB 2.2	6	194,440	
RB 2.3	6	272,590	
COMMONS 2C	1	4,650	
RB 2.4	5	125,240	
RB 2.5	6	171,612	
CC	4	155,568	
PARK & RIDE			50
SITE TOTALS:		2,130,406	1872

DEVELOPMENT SUMMARY

APN: 499-010-074-000, 499-010-075-000
 SITE AREA: ±55.56 ACRES (±2,420,193 SF)

EXISTING	ACRES	PERCENT
PERVIOUS AREA:	55.56 AC	100%
IMPERVIOUS SURFACE (PAVEMENTS)	0 AC	0%
IMPERVIOUS SURFACE (BUILDINGS)	0 AC	0%
TOTAL AREA:	55.56 AC	100%

PROPOSED	ACRES	PERCENT
PERVIOUS AREA (LANDSCAPE)	21.39 AC	38%
IMPERVIOUS SURFACE (PAVEMENTS)	20.21 AC	36%
IMPERVIOUS SURFACE (BUILDINGS)	13.97 AC	25%
TOTAL AREA:	55.56 AC	100%

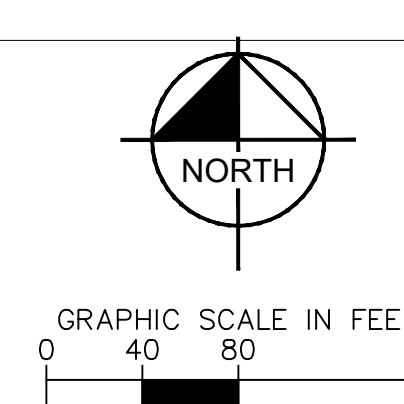





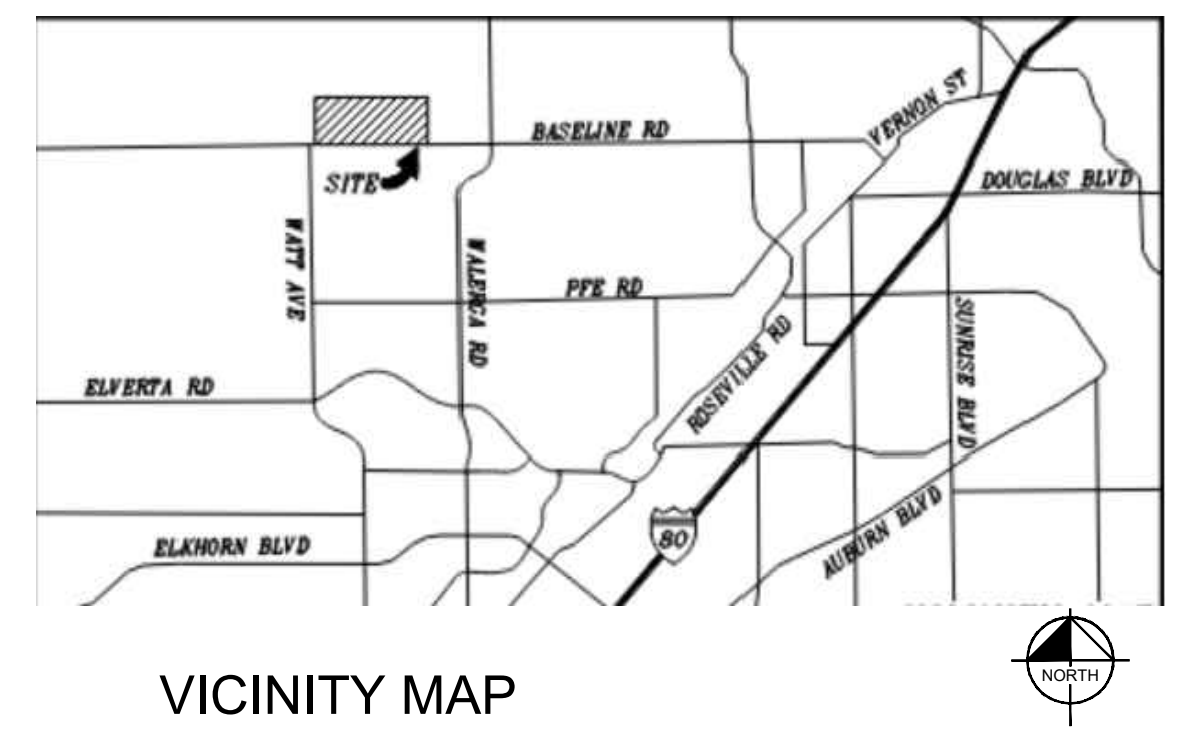

SIERRA VILLAGE DRIVE

SANTUCCI BOULEVARD

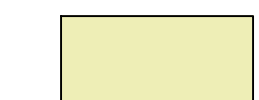
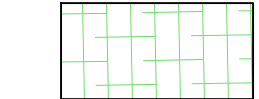

VICINITY MAP

LEGEND

-  ASPHALT PAVEMENT
-  LANDSCAPE AREA
-  CONCRETE SIDEWALK
-  BUILDING AREA
-  POTENTIAL CARPORT LOCATION
-  AMENDED SOILS AREA
-  FIRE TRUCK TURN RADII (30' INSIDE, 50' OUTSIDE)

MATCHLINE - SEE NEXT SHEET

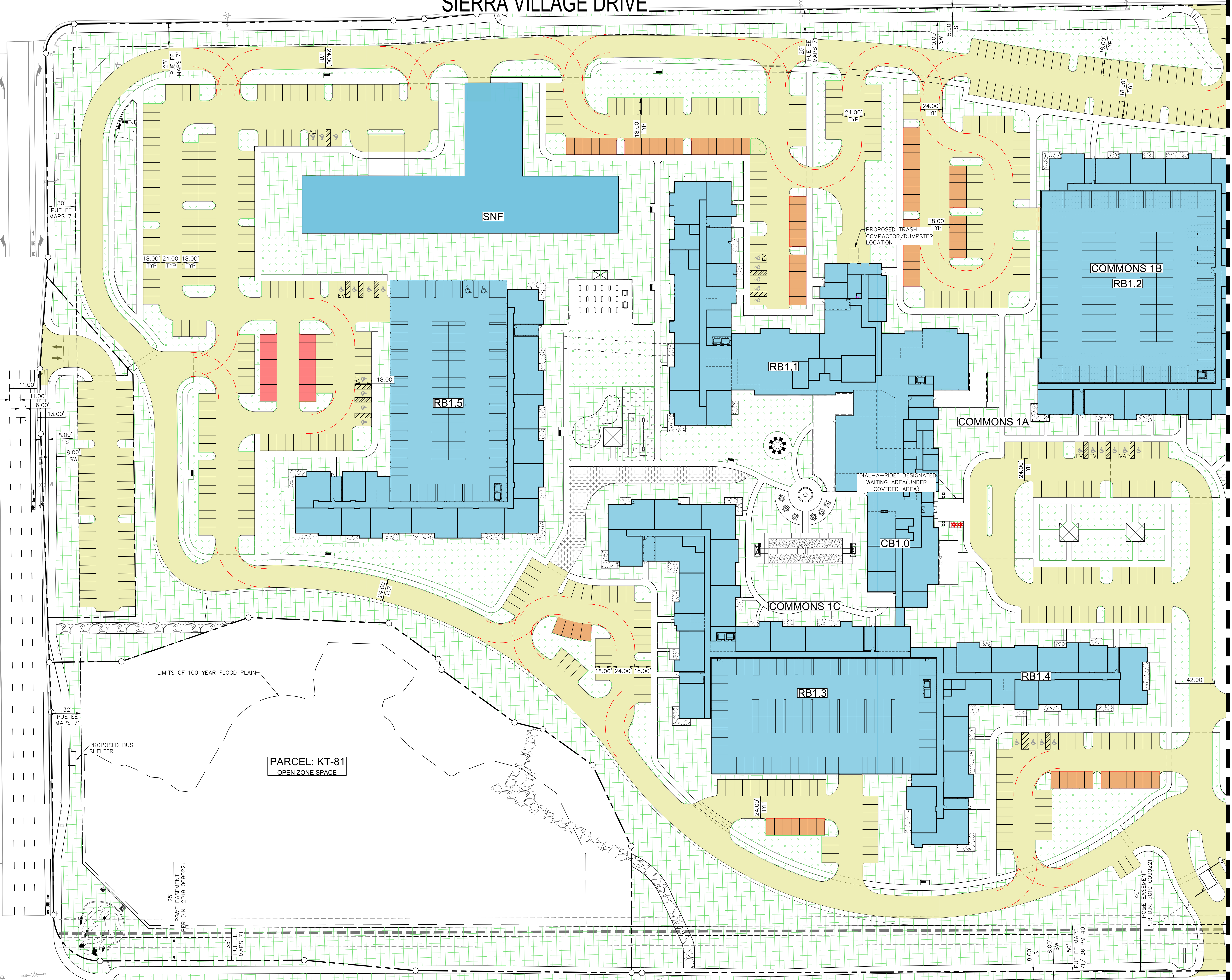

PARCEL: KT-81
OPEN ZONE SPACE

BASELINE ROAD

6000 BASELINE ROAD
ERICKSON SENIOR LIVING ROSEVILLE

MPP STAGE 1: SITE PLAN - WEST

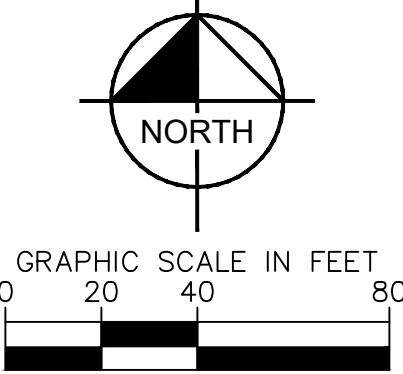

SIERRA VILLAGE DRIVE

WESTBROOK BOULEVARD

BASELINE ROAD

6000 BASELINE ROAD
ERICKSON SENIOR LIVING ROSEVILLE
MPP STAGE 1: SITE PLAN - EAST

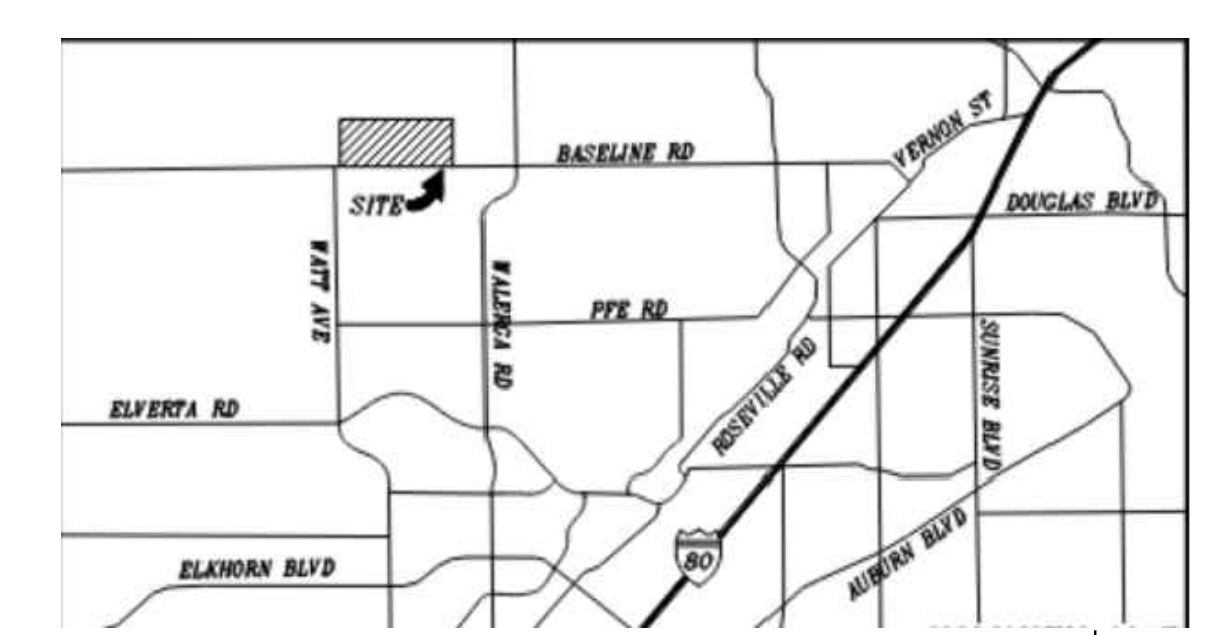

VICINITY MAP

LEGEND

- ASPHALT PAVEMENT
- LANDSCAPE AREA
- CONCRETE SIDEWALK
- BUILDING AREA
- POTENTIAL CARPORT LOCATION
- AMENDED SOILS AREA
- FIRE TRUCK TURN RADII (30' INSIDE, 50' OUTSIDE)

MATCHLINE - SEE PREVIOUS SHEET

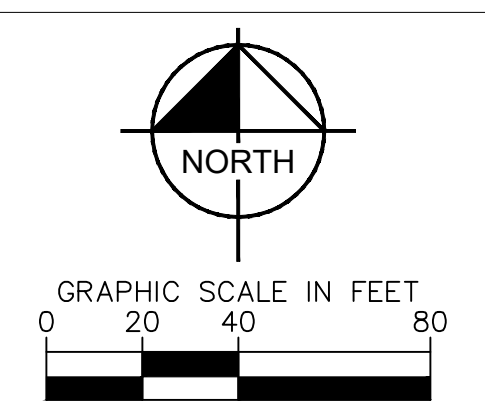
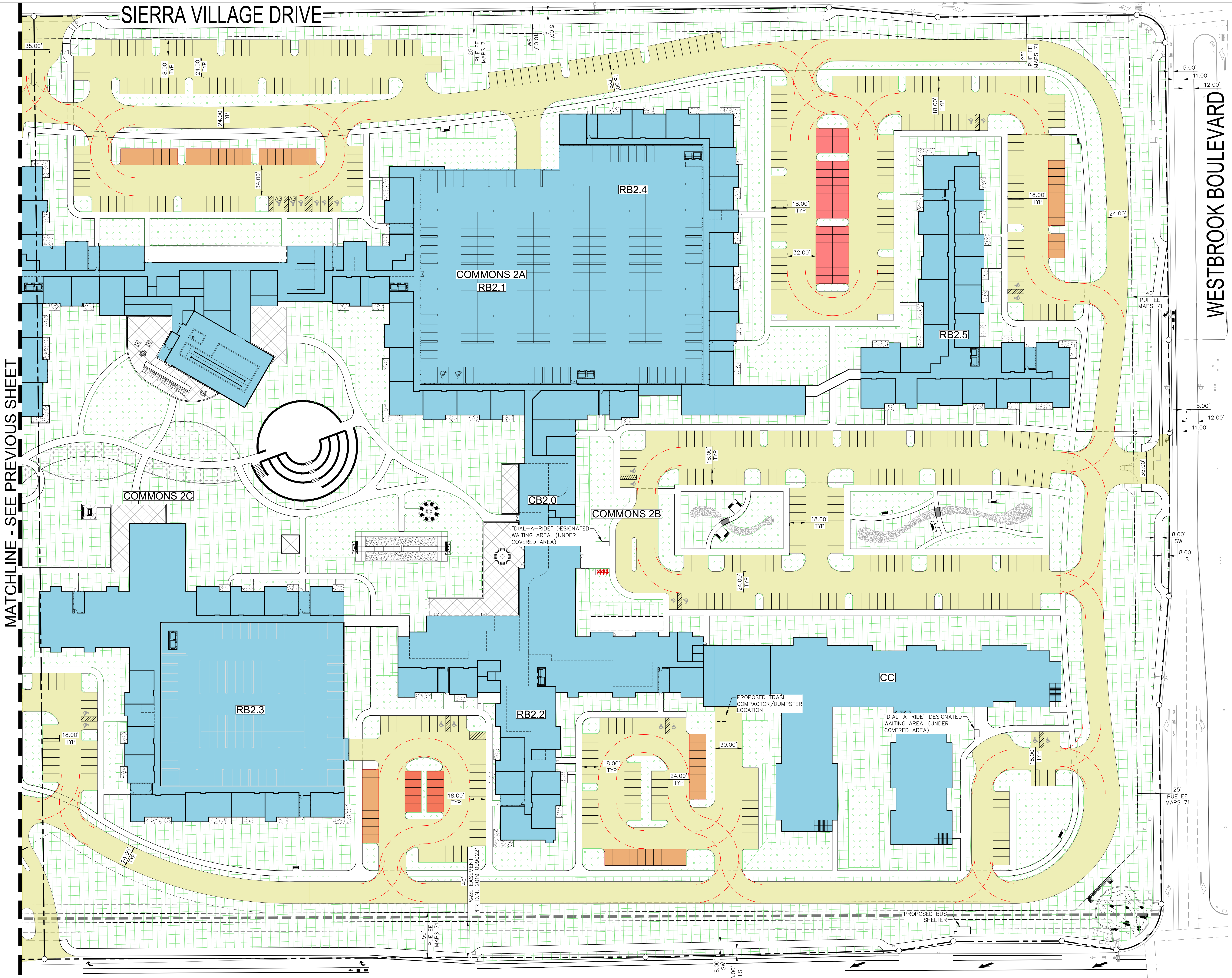

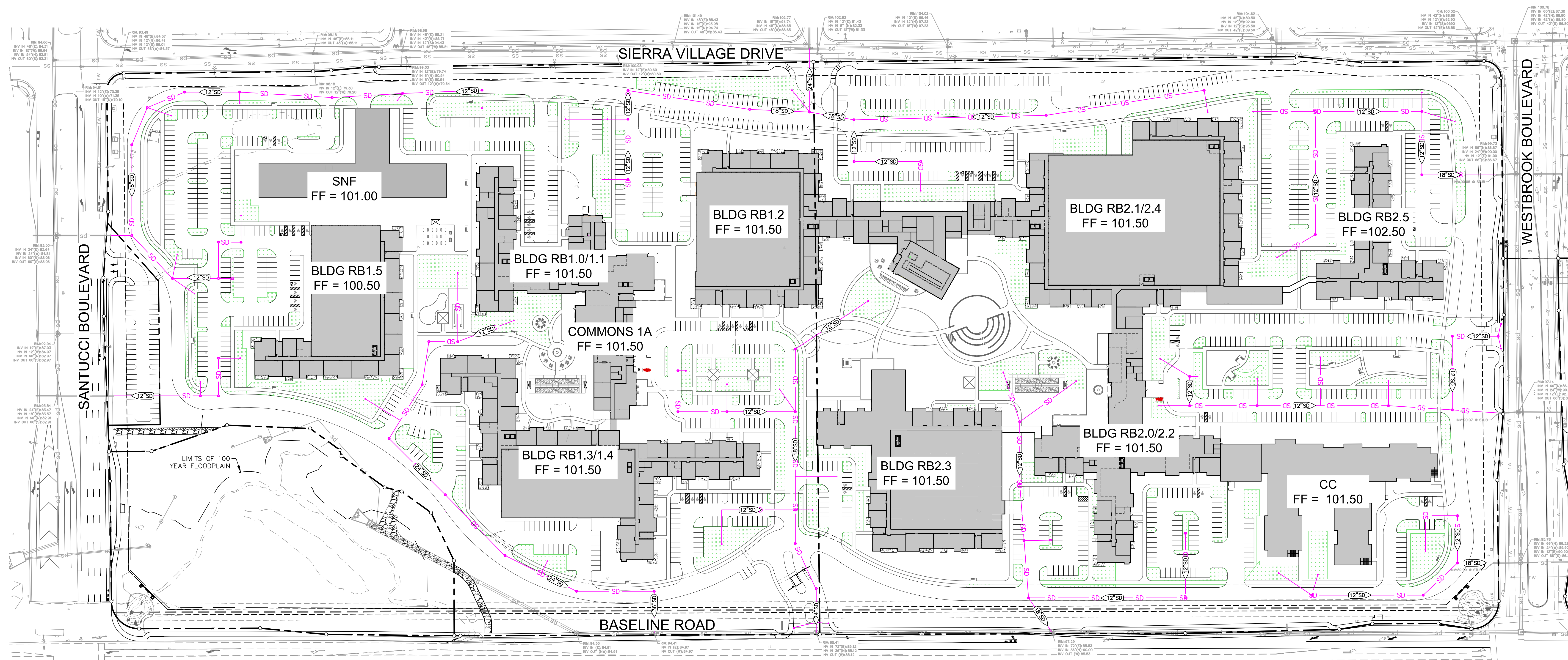

LEGEND

	CENTERLINE
	PROPERTY LINE
	RIGHT-OF-WAY LINE
	EASEMENT / SETBACK LINE
	APPROXIMATE CIVIL LIMIT OF WORK LINE
	PROPOSED STORM DRAIN PIPE
	EXISTING STORM DRAIN PIPE
	FLOW LINE
	LIMITS OF 100 YEAR FLOOD PLAN
	AMENDED SOILS AREA

VERTICAL DATUM
 NGVD 29 AS ADJUSTED TO THE COUNTY OF PLACER CITY BENCHMARK 126 (118.03) BEING A 3-1/4" BRASS DISK STAMPED SEPTEMBER 2014, LS-7331 LOCATED AT THE NORTHEAST CORNER OF THE INTERSECTION OF FIDDYMENT ROAD AND WESTLAKE DRIVE ON THE TOP OF CURB AT NORTH CURB RETURN.

6000 BASELINE ROAD
 ERICKSON SENIOR LIVING ROSEVILLE
MPP STAGE 1: GRADING PLAN

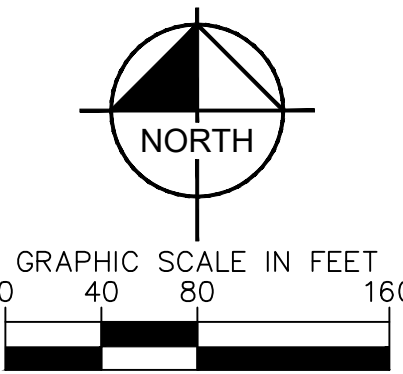

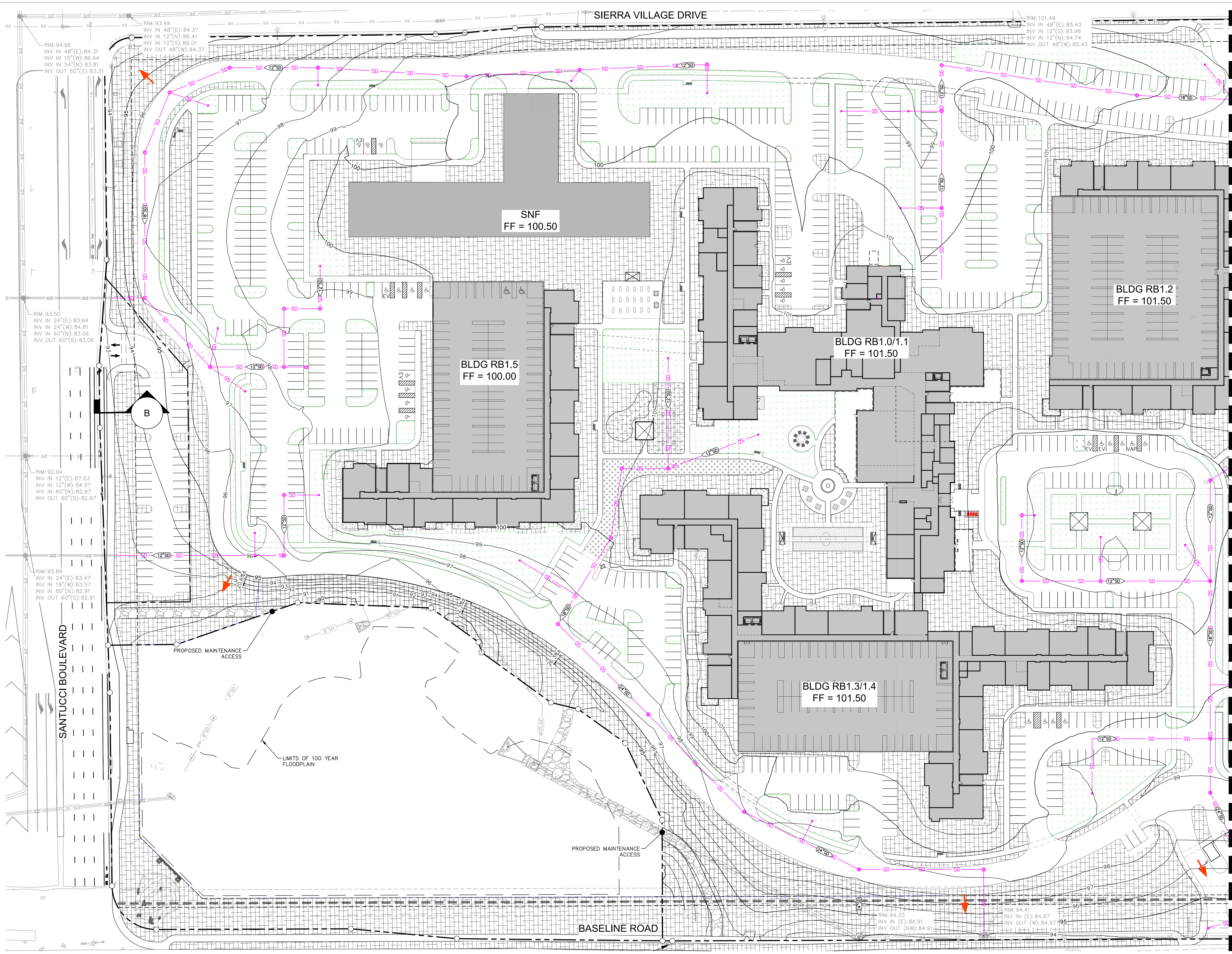

LEGEND

	CENTERLINE
	PROPERTY LINE
	RIGHT-OF-WAY LINE
	EASEMENT / SETBACK LINE
	APPROXIMATE CIVIL LIMIT OF WORK LINE
	PROPOSED STORM DRAIN PIPE
	EXISTING STORM DRAIN PIPE
	FLOW LINE
	OVERLAND RELEASE
	AMENDED SOILS AREA

MATCHLINE - SEE NEXT SHEET



February 10, 2023

6000 BASELINE ROAD
 ERICKSON SENIOR LIVING ROSEVILLE
 MPP STAGE 1: GRADING PLAN - WEST

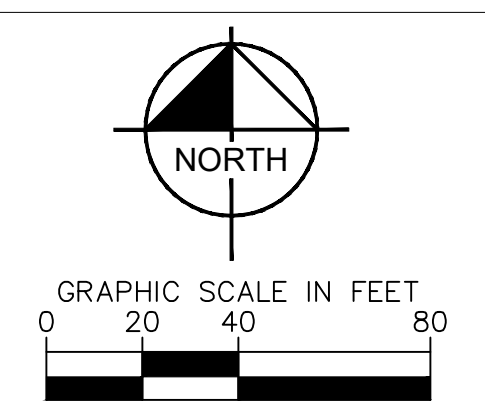

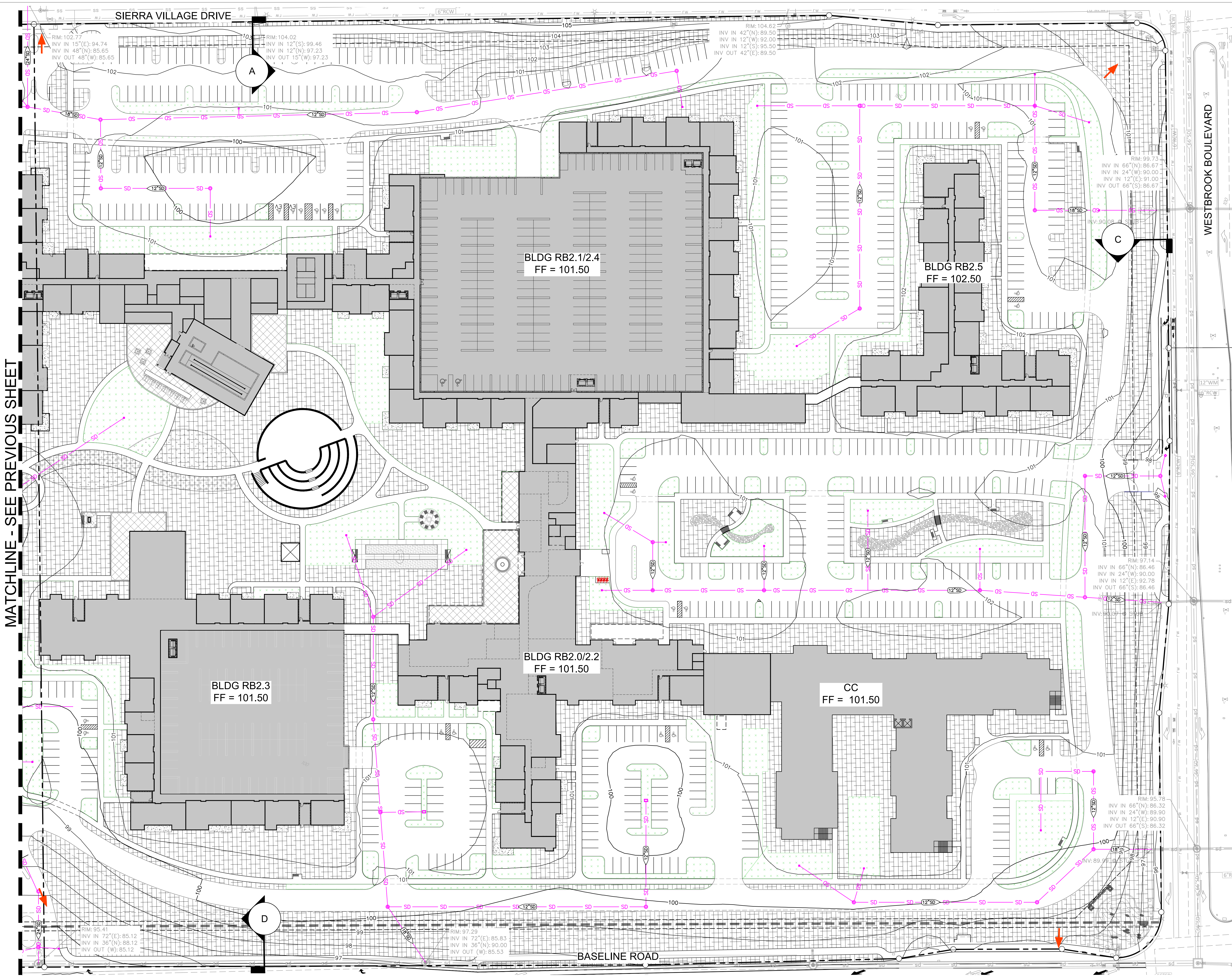

LEGEND

- CENTERLINE
- PROPERTY LINE
- RIGHT-OF-WAY LINE
- EASEMENT / SETBACK LINE
- APPROXIMATE CIVIL LIMIT OF WORK LINE
- PROPOSED STORM DRAIN PIPE
- EXISTING STORM DRAIN PIPE
- FLOW LINE
- OVERLAND RELEASE
- AMENDED SOILS AREA

MATCHLINE - SEE PREVIOUS SHEET

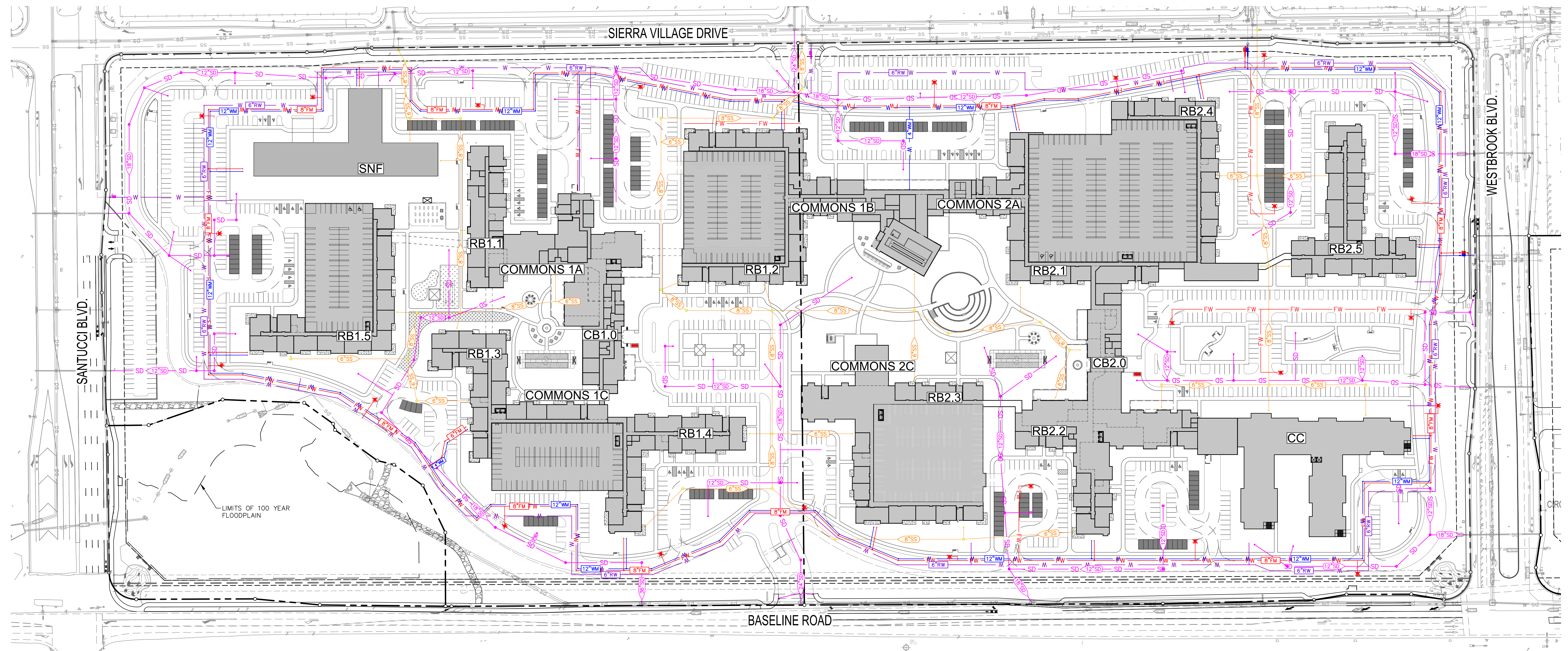

LEGEND

- **SS** 8"SS PROPOSED SEWER LINE
- **SD** 12"SD PROPOSED STORM DRAIN LINE
- **W** 12"W PROPOSED WATER LINE
- **FW** 8"FM PROPOSED FIRE WATER LINE
- **W** 6"RW PROPOSED RECLAIMED WATER LINE
- PROPOSED STORM DRAIN MANHOLE
- PROPOSED SEWER MANHOLE
- PROPOSED FIRE HYDRANT
- PROPOSED DOUBLE CHECK DETECTOR VALVE AND WATER METER

6000 BASELINE ROAD
ERICKSON SENIOR LIVING ROSEVILLE
MPP STAGE 1: WET UTILITIES PLAN

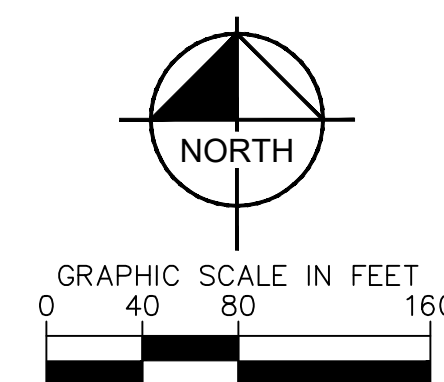

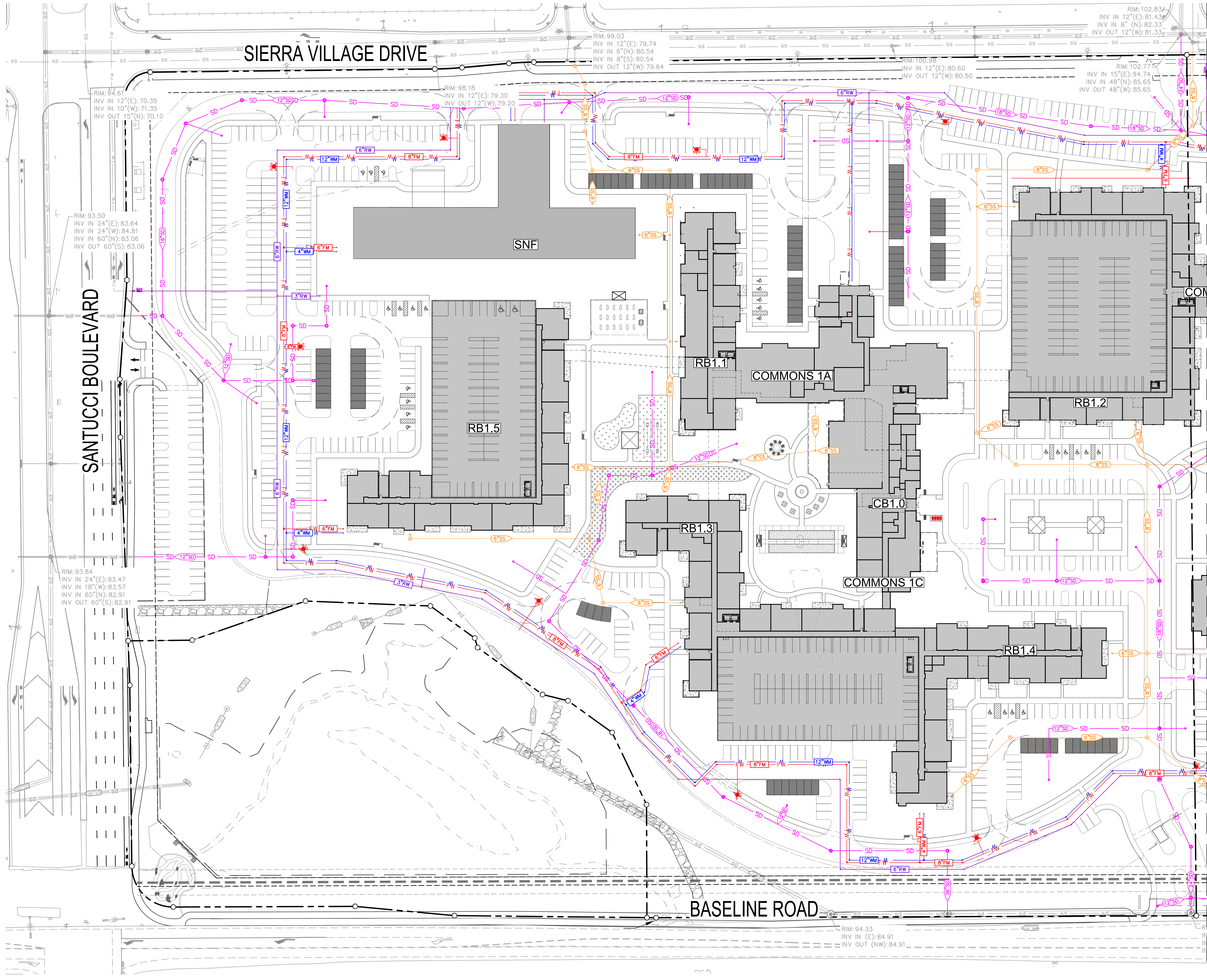

LEGEND

SS	8"SS	PROPOSED SEWER LINE
SD	12"SD	PROPOSED STORM DRAIN LINE
W	12"WM	PROPOSED WATER LINE
FW	8"FW	PROPOSED FIRE WATER LINE
W	8"RW	PROPOSED RECLAIMED WATER LINE
○		PROPOSED STORM DRAIN MANHOLE
●		PROPOSED SEWER MANHOLE
●		PROPOSED FIRE HYDRANT
●		PROPOSED DOUBLE CHECK DETECTOR VALVE AND WATER METER

MATCHLINE - SEE NEXT SHEET

LEGEND

- 8" SS PROPOSED SEWER LINE
- 12" SD PROPOSED STORM DRAIN LINE
- 12" WM PROPOSED WATER LINE
- 8" FM PROPOSED FIRE WATER LINE
- 12" RW PROPOSED RECLAIMED WATER LINE
- PROPOSED STORM DRAIN MANHOLE
- PROPOSED FIRE HYDRANT
- PROPOSED DOUBLE CHECK DETECTOR VALVE AND WATER METER

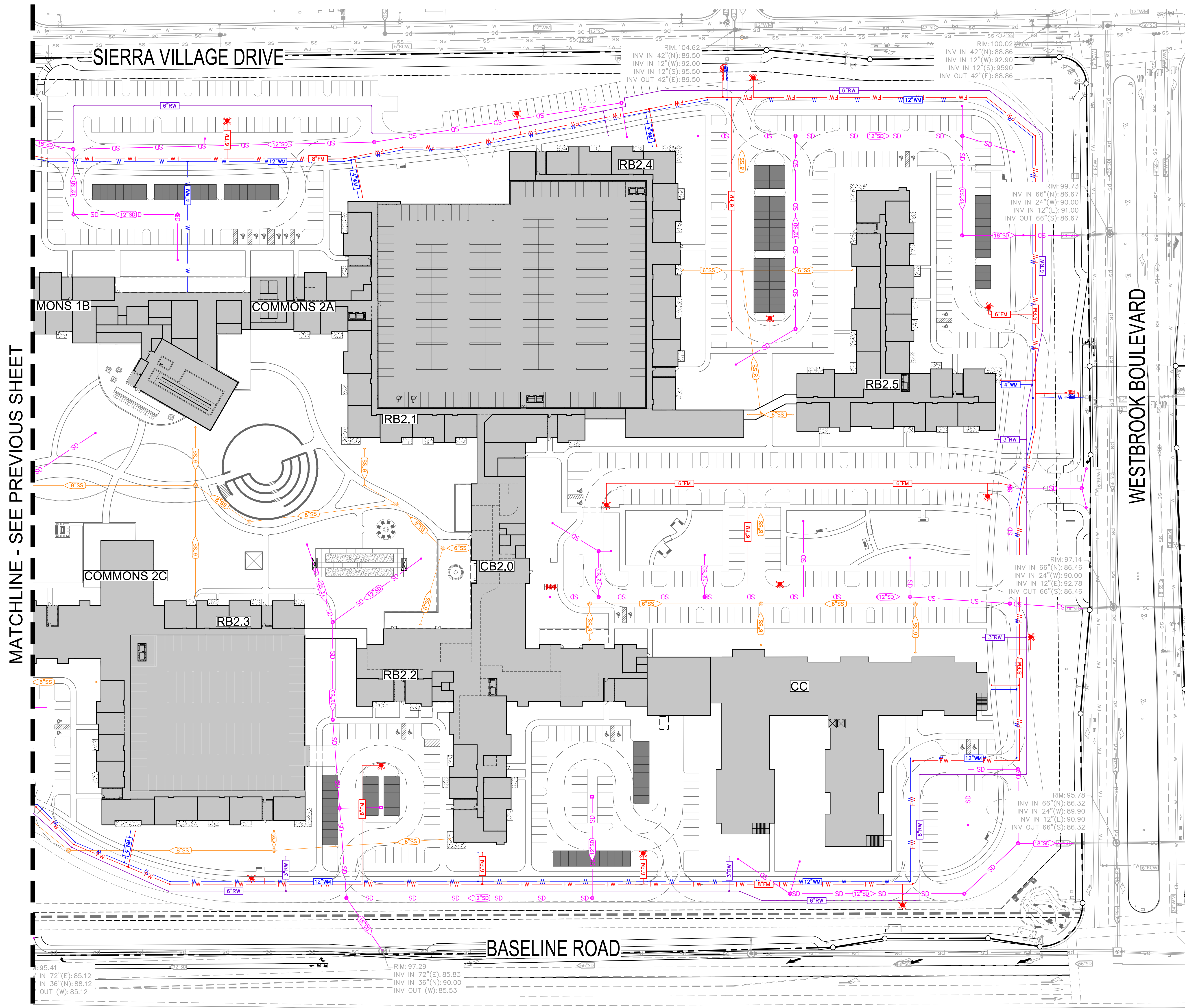

MATCHLINE - SEE PREVIOUS SHEET

LEGEND

- PRIMARY PEDESTRIAN PATHWAY
- ASPHALT PAVEMENT
- LANDSCAPE AREA

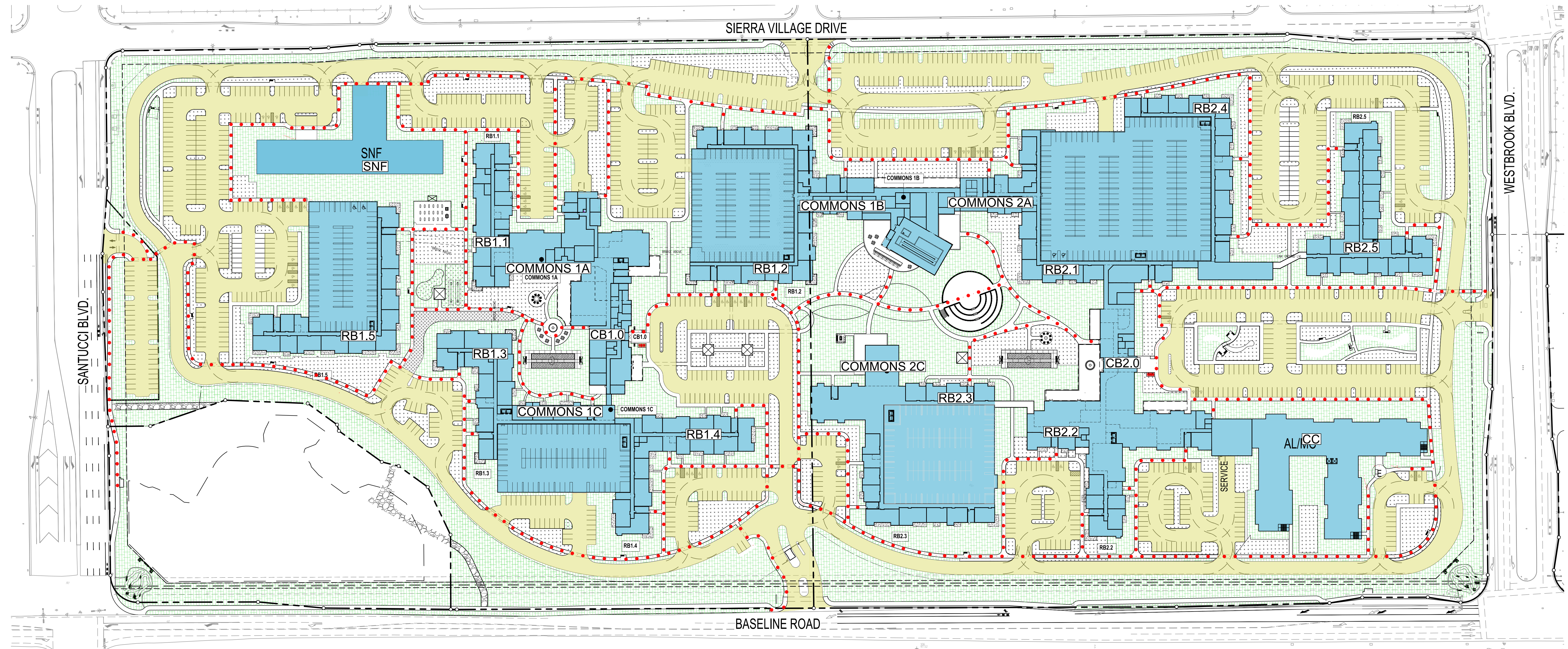

6000 BASELINE ROAD
ERICKSON SENIOR LIVING ROSEVILLE

Pedestrian Plan

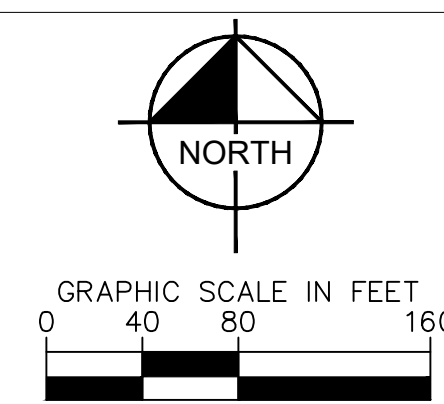

SIERRA VILLAGE DRIVE

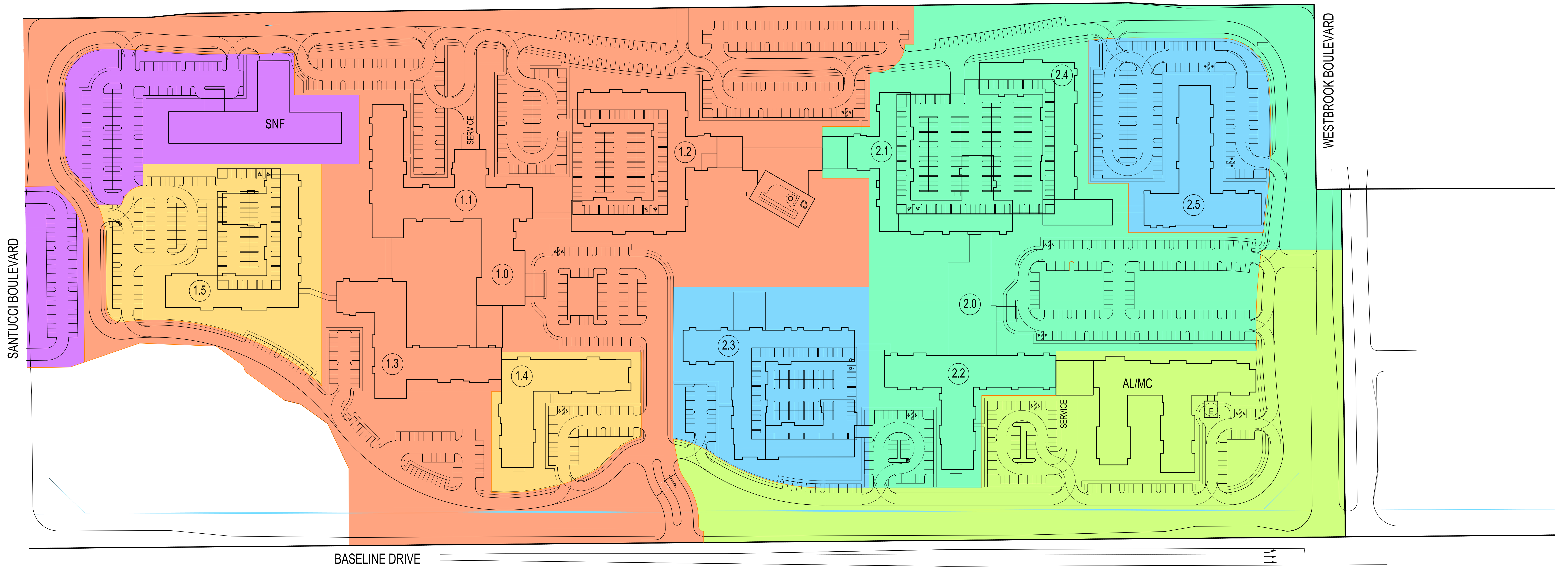

PARKING	BUILDINGS / COMMONS	SQUARE FOOTAGE	PARKING
PHASE 1	BUILDING RB 1.1/COMMONS 1A/COMMONS BUILDING 1.0	225,730	X
	BUILDING RB 1.2/COMMONS 1B	214,325	X
	BUILDING RB 1.3/COMMONS 1C	184,075	X
	TOTAL	624,130	X
PHASE 2	BUILDING RB 1.4	151,900	X
	BUILDING RB 1.5	198,409	X
TOTAL	350,309	X	
PHASE 3	CONTINUING CARE BUILDING	155,568	X
	TOTAL	155,568	X
PHASE 4	BUILDING RB 2.1/COMMONS 2A	185,528	X
	BUILDING RB 2.0 AND 2.2/COMMONS 2B	213,517	X
	BUILDING RB 2.4	125,240	X
	TOTAL	524,285	X
PHASE 5	BUILDING RB 2.3/COMMONS 2C	277,240	X
	BUILDING RB 2.5	171,612	X
	TOTAL	448,852	X
PHASE 6	SKILLED NURSING FACILITY (SNF)	27,262	X
	PARK AND RIDE LOT	0	X
	TOTAL	27,262	X
TOTAL SITE		2,130,406	1,852 SPACES

Erickson Senior Living Roseville
MPP Stage 1 Phasing Plan
Sierra Vista, West Roseville, CA

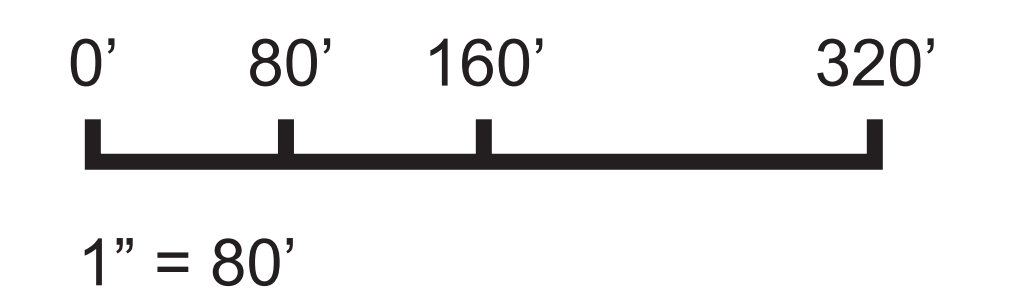

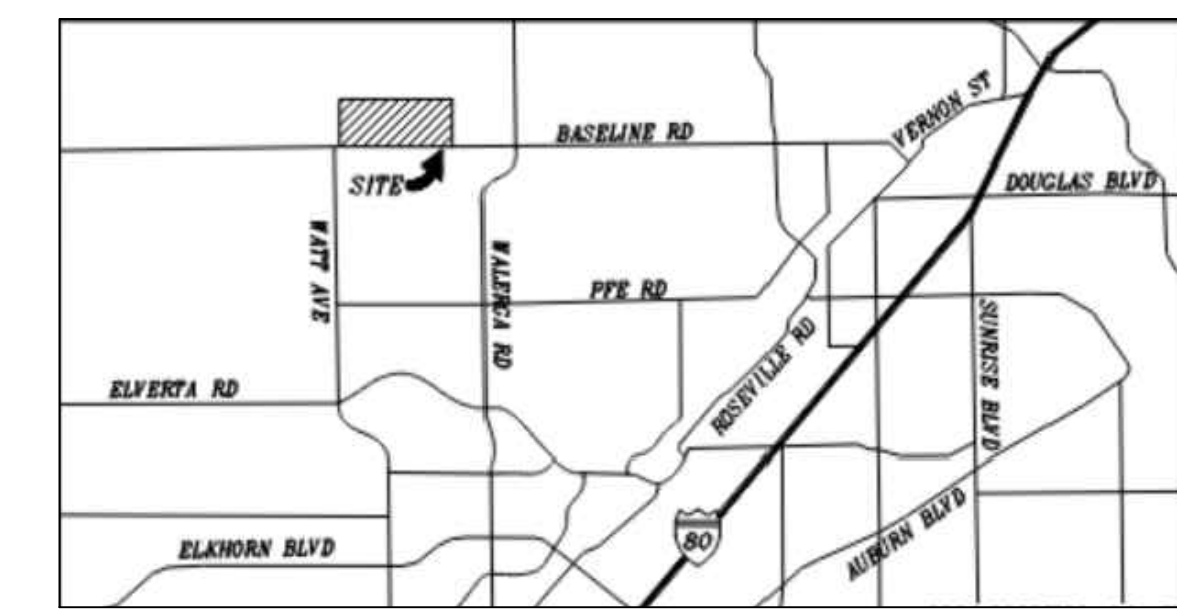

VICINITY MAP

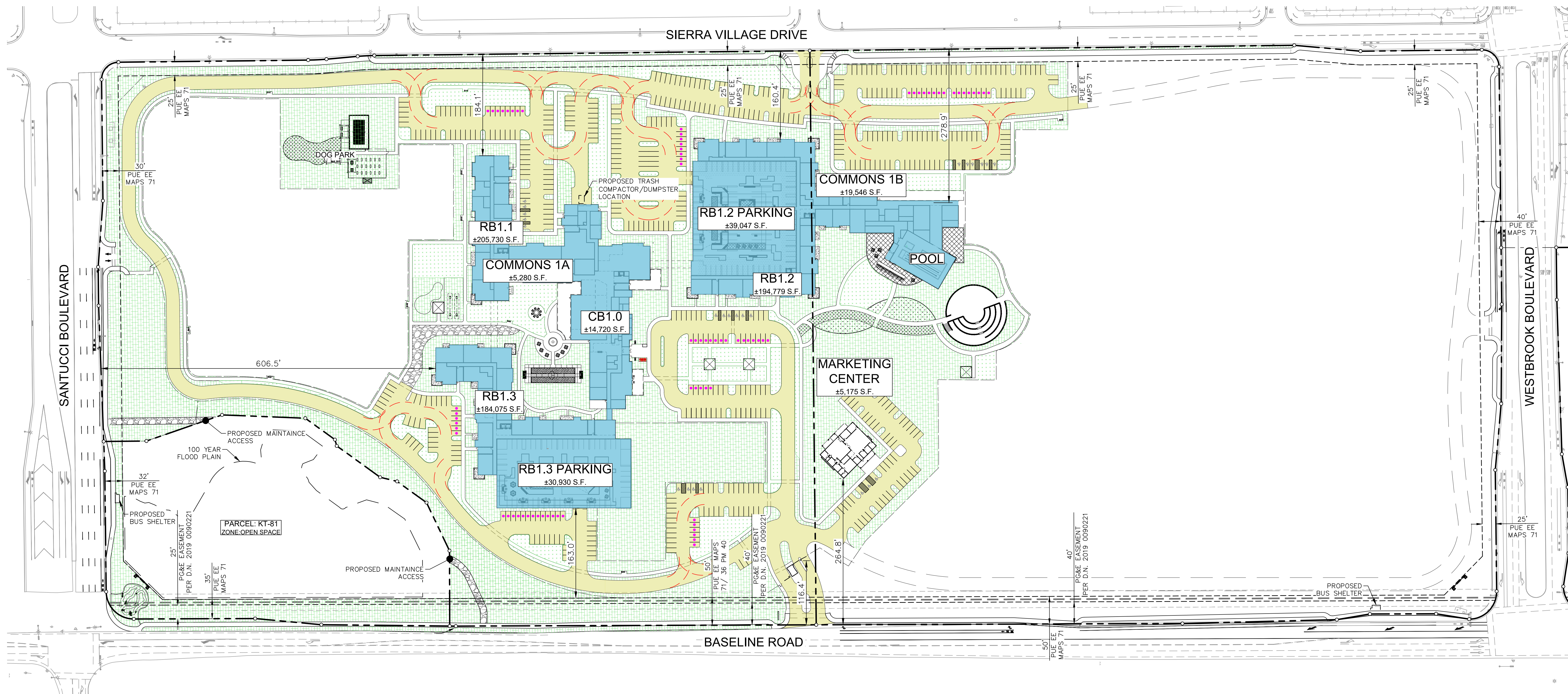
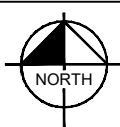

LEGEND

- ASPHALT PAVEMENT
- LANDSCAPE AREA
- CONCRETE SIDEWALK
- BUILDING AREA
- AMENDED SOILS AREA
- FIRE TRUCK RADIUS (TYP 30' & 50')

PROJECT SUMMARY

AREA
 AREA: 55.56± ACRES
 APN: 499-010-074-000, (LOT 1) (25.88 AC)
 APN: 499-010-075-000, (LOT 2) (29.68 AC)

SPECIFIC PLAN
 SIERRA VISTA SPECIFIC PLAN
 PARCELS KT-41A AND KT-41B

LAND USE DESIGNATION
 COMMUNITY COMMERCIAL (CC)

ZONING
 GENERAL COMMERCIAL (GC)

PROPOSED USES
 COMMUNITY CARE FACILITY,
 LONG-TERM CARE FACILITY,
 AND MEDICAL SERVICES

DEVELOPER
 ERICKSON SENIOR LIVING, LLC
 701 MAIDEN CHOICE LANE
 BALTIMORE, MD 21228
 ATTN: STEVEN MONTGOMERY

PROPERTY OWNER
 KV SIERRA VISTA, LLC
 7700 COLLEGE TOWN DR, SUITE 101
 SACRAMENTO, CA 95826

ENGINEER
 KIMLEY-HORN AND ASSOCIATES
 555 CAPITOL MALL SUITE 300
 SACRAMENTO, CA 95814
 ATTN: FAREED PITTALWALA

ARCHITECT
 LANITZ-BOGGIO
 9550 DTC PARKWAY, SUITE 200
 ENGLEWOOD, CO 80111
 ATTN: DAVID FIK

BUILDING SUMMARY

BUILDING	STORIES	SQUARE FEET
RB 1.1	5	205,730
CB 1.0	1	14,720
COMMONS 1A	1	5,280
RB 1.2	5	194,779
COMMONS 1B	1	19,546
RB 1.3	6	184,075
MARKETING CENTER	1	5,175
SITE TOTALS:		629,305

	STANDARD SPACES	555
Stage 2	PODIUM PARKING	191
	ADA SPACES	28
	Total	774

CALGREEN REQUIREMENTS
 ELECTRIC VEHICLE CHARGING CAPABLE
 (10% OF 774) 77



February 9, 2023

6000 BASELINE ROAD
 ERICKSON SENIOR LIVING ROSEVILLE
MPP STAGE 2: SITE PLAN

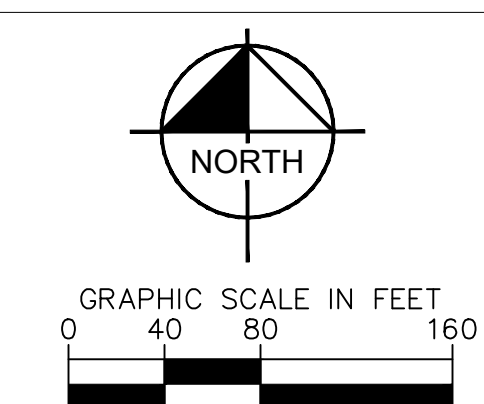

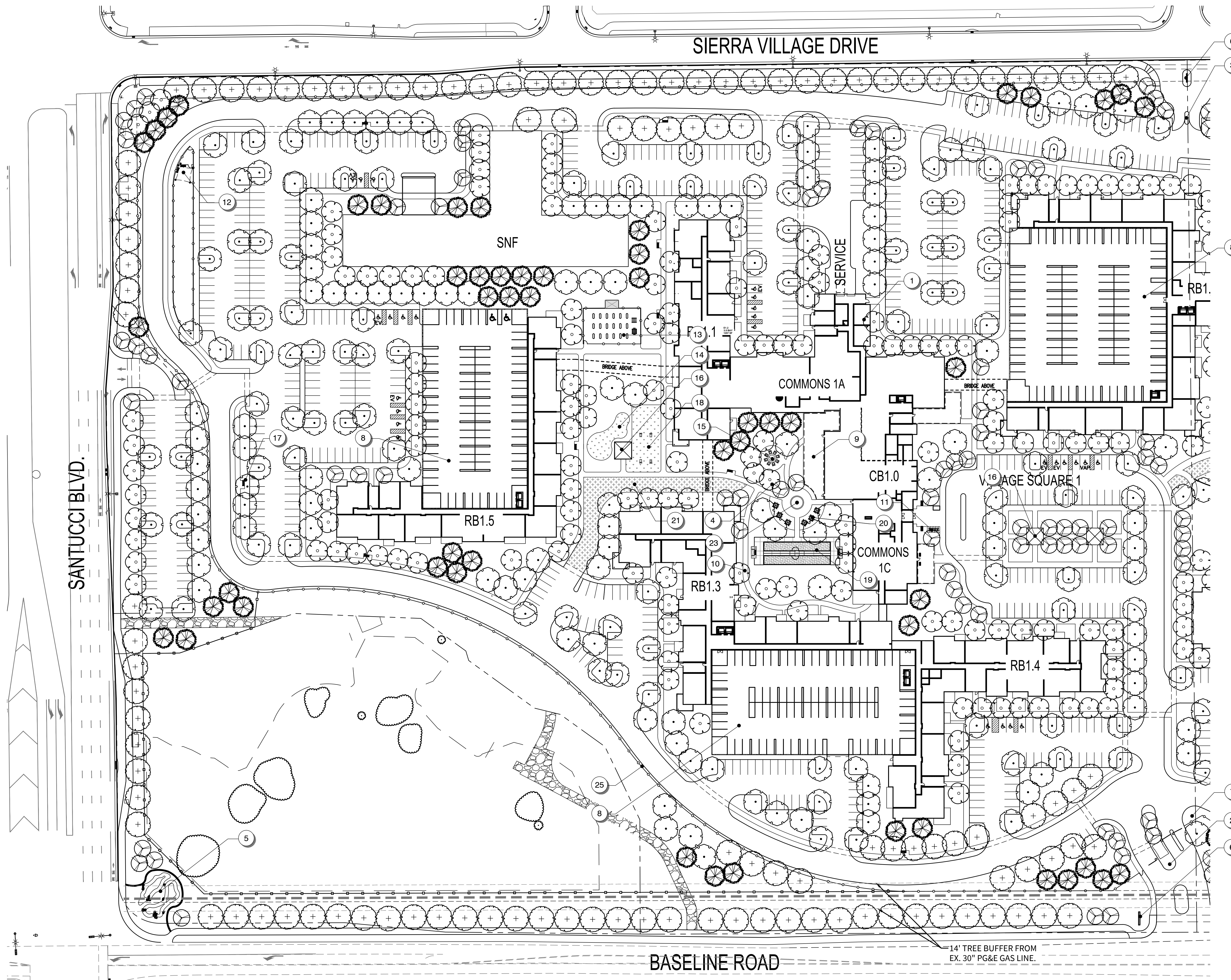

CONCEPT PLANT SCHEDULE

- SHADE TREES
 - ACER RUBRUM 'OCTOBER GLORY' / OCTOBER GLORY RED MAPLE (40'X35')
 - CELTIS OCCIDENTALIS / CHINESE HACKBERRY (40'X40')
 - PISTACIA CHINENSIS / CHINESE PISTACHE (40'X40')
 - ZELKOVA SERRATA 'VILLAGE GREEN' / VILLAGE GREEN SAWLEAF ZELKOVA (50'X35')
- SCREEN TREES
 - CEDRUS DEODARA / DEODAR CEDAR (60'X40")
 - PODOCARPUS GRACILIOR / FERN PINE (40'X20")
 - QUERCUS ILEX / HOLLY OAK (60'X40")
- ACCENT TREES
 - CERCIS OCCIDENTALIS / WESTERN REDBUD (18'X18')
 - LAGERSTROEMIA INDICA X FAURIEI 'ARAPAHO' / RED CRAPE MYRTLE (25'X20')
 - MAGNOLIA GRANDIFLORA 'LITTLE GEM' / LITTLE GEM DWARF MAGNOLIA (25'X15')
 - X CHITALPA TASHKENTENSIS 'PINK DAWN' / PINK DAWN CHITALPA (30'X25')
- SUBORDINATE TREES
 - ACER BUERGERIANUM / TRIDENT MAPLE (25'X25')
 - GINKGO BILOBA 'PRINCETON SENTINEL' / MAIDENHAIR TREE (40'X20')
 - KOELREUTERIA PANICULATA / GOLDEN RAIN TREE (35'X30')
 - ZELKOVA SERRATA 'MUSASHINO' / MUSASHINO SAWLEAF ZELKOVA (40'X15')
- STREET TREE
 - LIRIODENDRON TULIPIFERA / TULIP TREE (60'X40')
 - QUERCUS RUBRA / RED OAK (60'X45')

REFERENCE NOTES SCHEDULE

- | SYMBOL | DESCRIPTION |
|--------|--|
| 1 | PROPOSED BUILDINGS - SEE ARCHITECTURAL PLANS. |
| 2 | PROPOSED MAIN ENTRY WITH GATE HOUSE. |
| 3 | PROPOSED SECONDARY ENTRY. |
| 4 | PROPOSED STORMWATER BASINS - SEE CIVIL PLANS. |
| 5 | PROPOSED ACCENT PLANTING AT PROJECT CORNERS. |
| 6 | PROPOSED PROJECT MONUMENT SIGN (TYP. OF 3) |
| 7 | PROPOSED FLAG POLES (TYP. OF 3) |
| 8 | PROPOSED SEATING / AMENITY AREA ON ROOF DECK. |
| 9 | PROPOSED OUTDOOR DINING PATIOS. |
| 10 | PROPOSED SIDEWALKS. |
| 11 | PROPOSED SHORT TERM BIKE RACKS. |
| 12 | PROPOSED DOG PARK. |
| 13 | PROPOSED COMMUNITY GARDEN. |
| 14 | PROPOSED PUTTING GREEN. |
| 15 | PROPOSED FIRE PIT. |
| 16 | PROPOSED SEATING AREA WITH SHADE SHELTER. |
| 17 | PROPOSED BENCHES ON PERIMETER WALKING PATH. |
| 18 | PROPOSED OPEN TURF AREAS. |
| 19 | PROPOSED BOCCIE COURTS. |
| 20 | PROPOSED TABLE AND CHAIRS WITH UMBRELLAS. |
| 21 | PROPOSED SYNTHETIC TURF ON PAVERS FOR FIRE ACCESS. |
| 22 | PROPOSED SUN DECK WITH FURNITURE. |
| 23 | PROPOSED WATER FEATURE. |
| 24 | PROPOSED AMPHITHEATER. |
| 25 | PROPOSED OPEN METAL FENCE. |
| 26 | PROPOSED DRY CREEK BED. |

SANTUCCI BLVD.

SIERRA VILLAGE DRIVE

BASELINE ROAD

14' TREE BUFFER FROM EX. 30" PG&E GAS LINE.

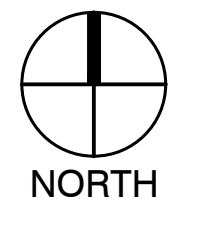

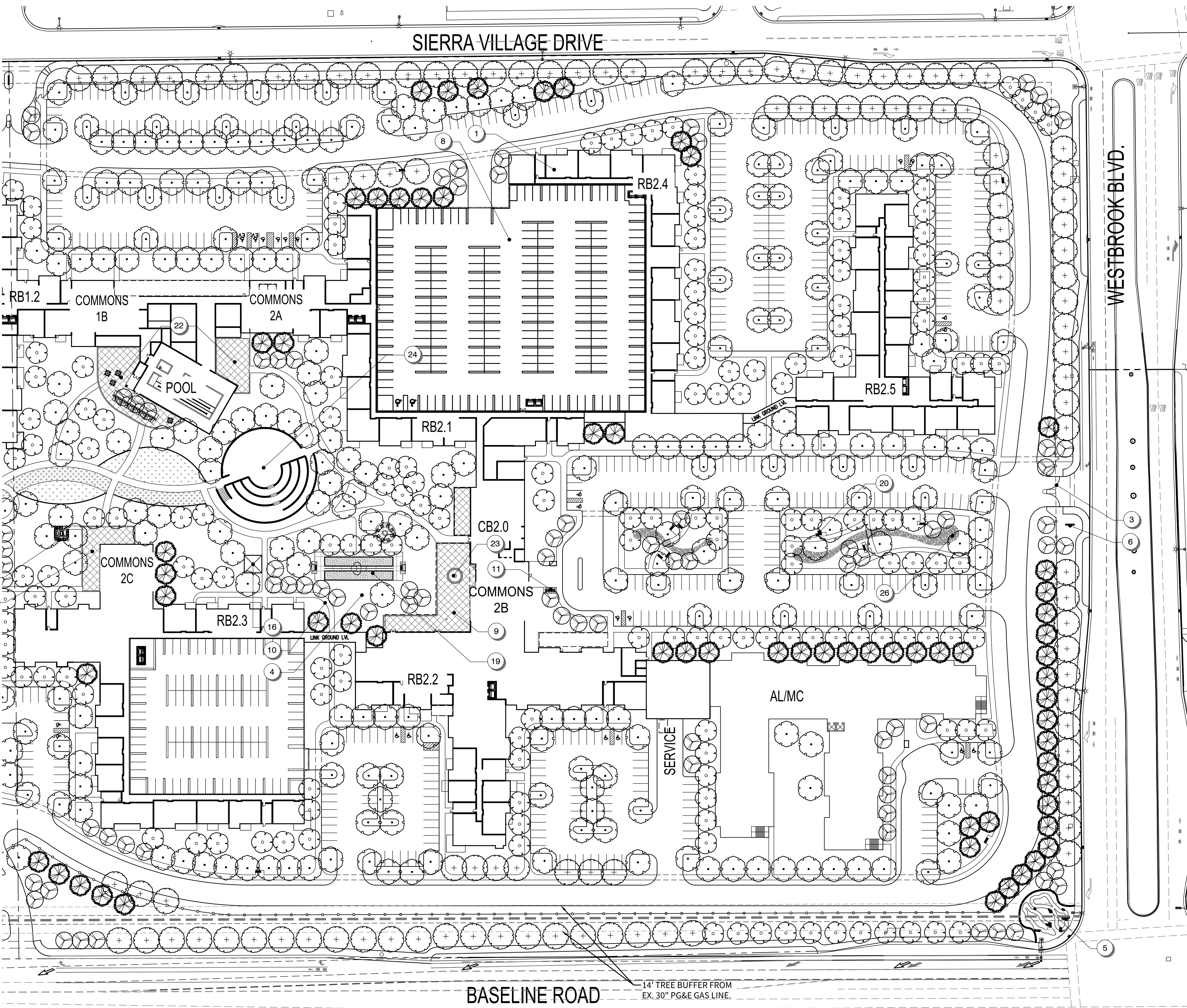

CONCEPT PLANT SCHEDULE

	<p>SHADE TREES ACER RUBRUM 'OCTOBER GLORY' / OCTOBER GLORY RED MAPLE (40'X35') CÉLTIS OCCIDENTALIS / CHINESE HACKBERRY (40'X40') PISTACIA CHINENSIS / CHINESE PISTACHE (40'X40') ZELKOVA SERRATA 'VILLAGE GREEN' / VILLAGE GREEN SAWLEAF ZELKOVA (50'X35')</p>
	<p>SCREEN TREES CEDRUS DEODARA / DEODAR CEDAR (60'X40") PODOCARPUS GRACILIOR / FERN PINE (40'X20") QUERCUS ILEX / HOLLY OAK (60'X40")</p>
	<p>ACCENT TREES CERCIS OCCIDENTALIS / WESTERN REDBUD (18'X18") LAGERSTROEMIA INDICA X FAURIEI 'ARAPAHO' / RED CRAPE MYRTLE (25'X20") MAGNOLIA GRANDIFLORA 'LITTLE GEM' / LITTLE GEM DWARF MAGNOLIA (25'X15") X CHITALPA TASHKENTENSIS 'PINK DAWN' / PINK DAWN CHITALPA (30'X25")</p>
	<p>SUBORDINATE TREES ACER BUERGERIANUM / TRIDENT MAPLE (25'X25") GINKGO BILOBA 'PRINCETON SENTINEL' / MAIDENHAIR TREE (40'X20") KOELREUTERIA PANICULATA / GOLDEN RAIN TREE (35'X30") ZELKOVA SERRATA 'MUSASHINO' / MUSASHINO SAWLEAF ZELKOVA (40'X15")</p>
	<p>STREET TREE LIRODENDRON TULIPIFERA / TULIP TREE (60'X40") QUERCUS RUBRA / RED OAK (60'X45")</p>

REFERENCE NOTES SCHEDULE

SYMBOL	DESCRIPTION
1	PROPOSED BUILDINGS - SEE ARCHITECTURAL PLANS.
2	PROPOSED MAIN ENTRY WITH GATE HOUSE.
3	PROPOSED SECONDARY ENTRY.
4	PROPOSED STORMWATER BASINS - SEE CIVIL PLANS.
5	PROPOSED ACCENT PLANTING AT PROJECT CORNERS.
6	PROPOSED PROJECT MONUMENT SIGN (TYP. OF 3)
7	PROPOSED FLAG POLES (TYP. OF 3)
8	PROPOSED SEATING / AMENITY AREA ON ROOF DECK.
9	PROPOSED OUTDOOR DINING PATIOS.
10	PROPOSED SIDEWALKS.
11	PROPOSED SHORT TERM BIKE RACKS.
12	PROPOSED DOG PARK.
13	PROPOSED COMMUNITY GARDEN.
14	PROPOSED PUTTING GREEN.
15	PROPOSED FIRE PIT.
16	PROPOSED SEATING AREA WITH SHADE SHELTER.
17	PROPOSED BENCHES ON PERIMETER WALKING PATH.
18	PROPOSED OPEN TURF AREAS.
19	PROPOSED BOCCIE COURTS.
20	PROPOSED TABLE AND CHAIRS WITH UMBRELLAS.
21	PROPOSED SYNTHETIC TURF ON PAVERS FOR FIRE ACCESS.
22	PROPOSED SUN DECK WITH FURNITURE.
23	PROPOSED WATER FEATURE.
24	PROPOSED AMPHITHEATER.
25	PROPOSED OPEN METAL FENCE.
26	PROPOSED DRY CREEK BED.

FUHRMAN LEAMY LAND GROUP
 DESIGN · SERVICE · SOLUTIONS
 2140 PROFESSIONAL DRIVE, SUITE 115 ROSEVILLE, CA 95661
 (916) 783-5263 info@fllandgroup.com

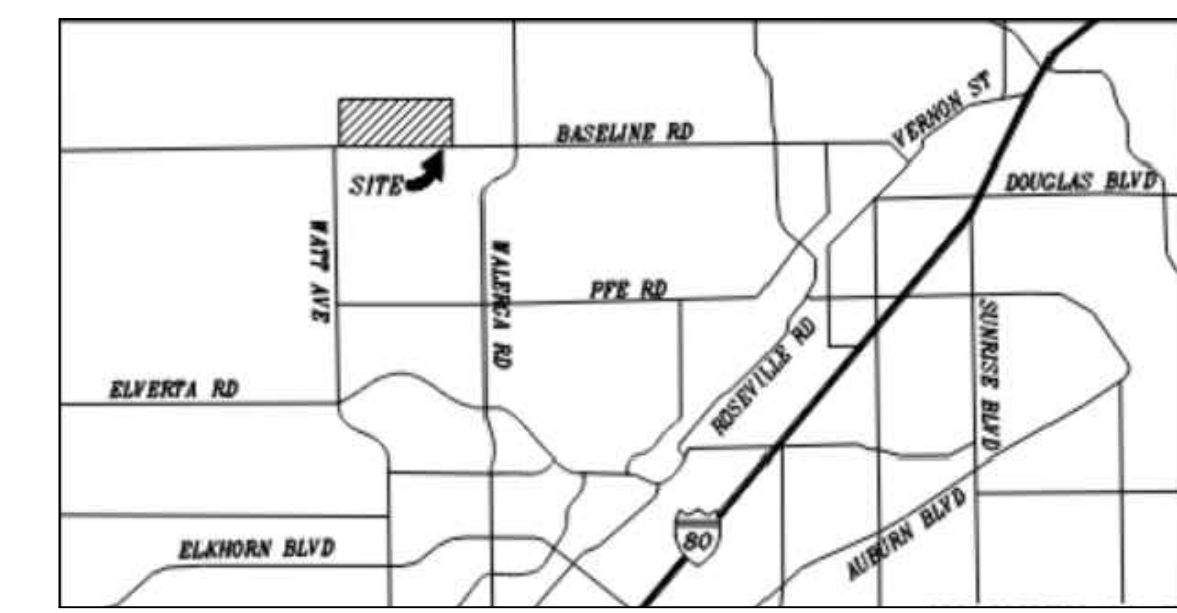

VICINITY MAP

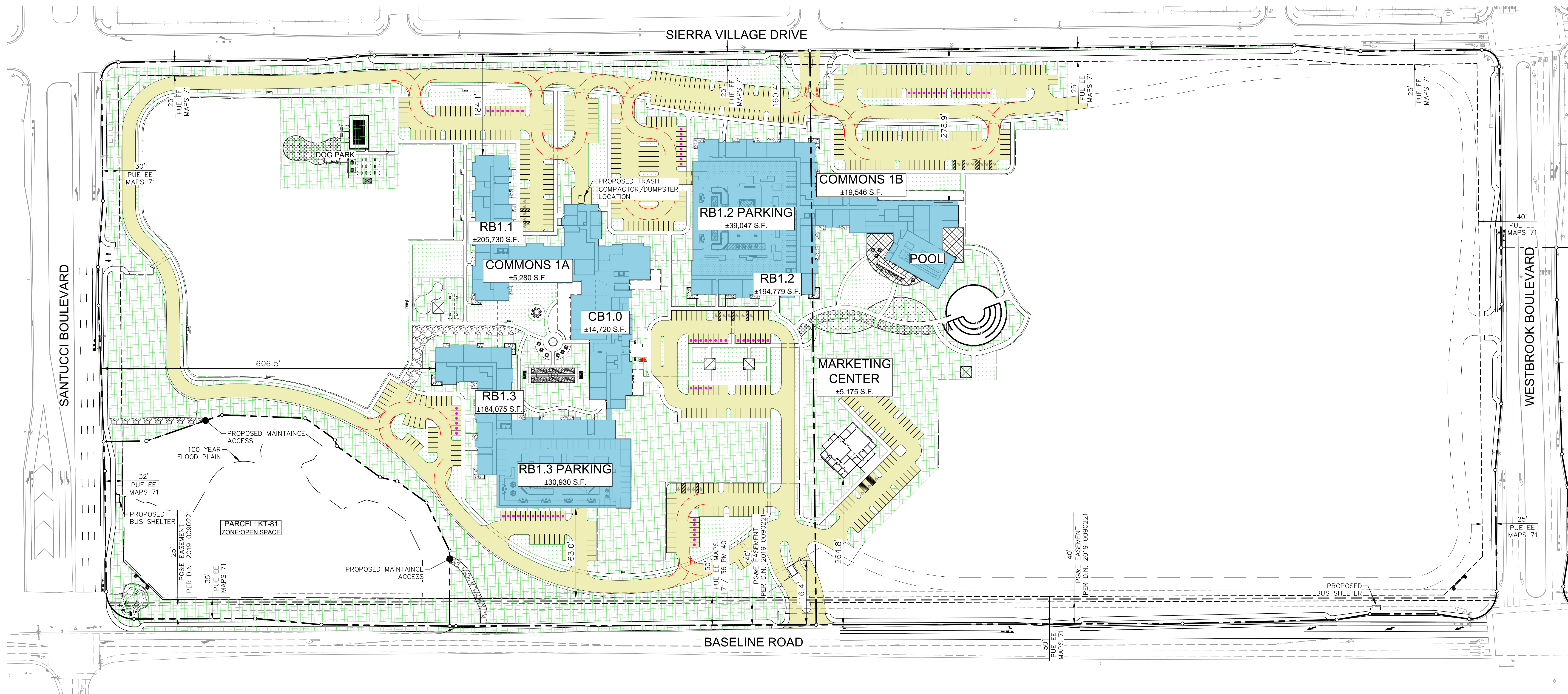
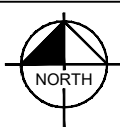

LEGEND

- ASPHALT PAVEMENT
- LANDSCAPE AREA
- CONCRETE SIDEWALK
- BUILDING AREA
- AMENDED SOILS AREA
- FIRE TRUCK RADIUS (TYP 30' & 50')

PROJECT SUMMARY

AREA
 AREA: 55.56± ACRES
 APN: 499-010-074-000, (LOT 1) (25.88 AC)
 APN: 499-010-075-000, (LOT 2) (29.68 AC)

SPECIFIC PLAN
 SIERRA VISTA SPECIFIC PLAN
 PARCELS KT-41A AND KT-41B

LAND USE DESIGNATION
 COMMUNITY COMMERCIAL (CC)

ZONING
 GENERAL COMMERCIAL (GC)

PROPOSED USES
 COMMUNITY CARE FACILITY,
 LONG-TERM CARE FACILITY,
 AND MEDICAL SERVICES

DEVELOPER
 ERICKSON SENIOR LIVING, LLC
 701 MARDEN CHOICE LANE
 BALTIMORE, MD 21228
 ATTN: STEVEN MONTGOMERY

PROPERTY OWNER
 KV SIERRA VISTA, LLC
 7700 COLLEGE TOWN DR, SUITE 101
 SACRAMENTO, CA 95826

ENGINEER
 KIMLEY-HORN AND ASSOCIATES
 555 CAPITOL MALL SUITE 300
 SACRAMENTO, CA 95814
 ATTN: FAREED PITTALWALA

ARCHITECT
 LANITZ-BOGGIO
 9550 DTC PARKWAY, SUITE 200
 ENGLEWOOD, CO 80111
 ATTN: DAVID FIK

BUILDING SUMMARY

BUILDING	STORIES	SQUARE FEET
RB 1.1	5	205,730
CB 1.0	1	14,720
COMMONS 1A	1	5,280
RB 1.2	5	194,779
COMMONS 1B	1	19,546
RB 1.3	6	184,075
MARKETING CENTER	1	5,175
SITE TOTALS:		629,305

	STANDARD SPACES	555
Stage 2	PODIUM PARKING	191
	ADA SPACES	28
	Total	774

CALGREEN REQUIREMENTS
 ELECTRIC VEHICLE CHARGING CAPABLE
 (10% OF 774) **77**



February 9, 2023

6000 BASELINE ROAD
 ERICKSON SENIOR LIVING ROSEVILLE
MPP STAGE 2: SITE PLAN

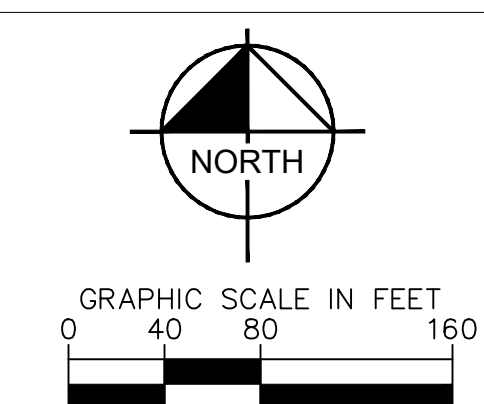

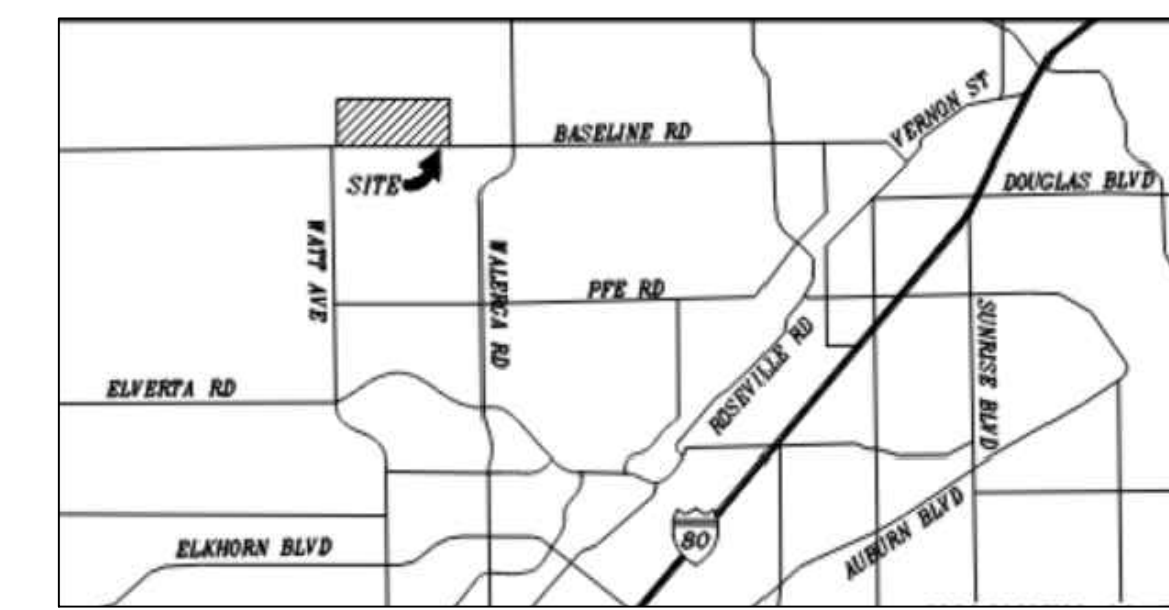





VICINITY MAP

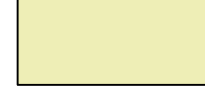
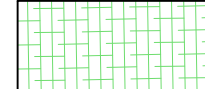

LEGEND

-  ASPHALT PAVEMENT
-  LANDSCAPE AREA
-  CONCRETE SIDEWALK
-  BUILDING AREA
-  AMENDED SOILS AREA
-  FIRE TRUCK RADIUS (TYP 30' & 50')

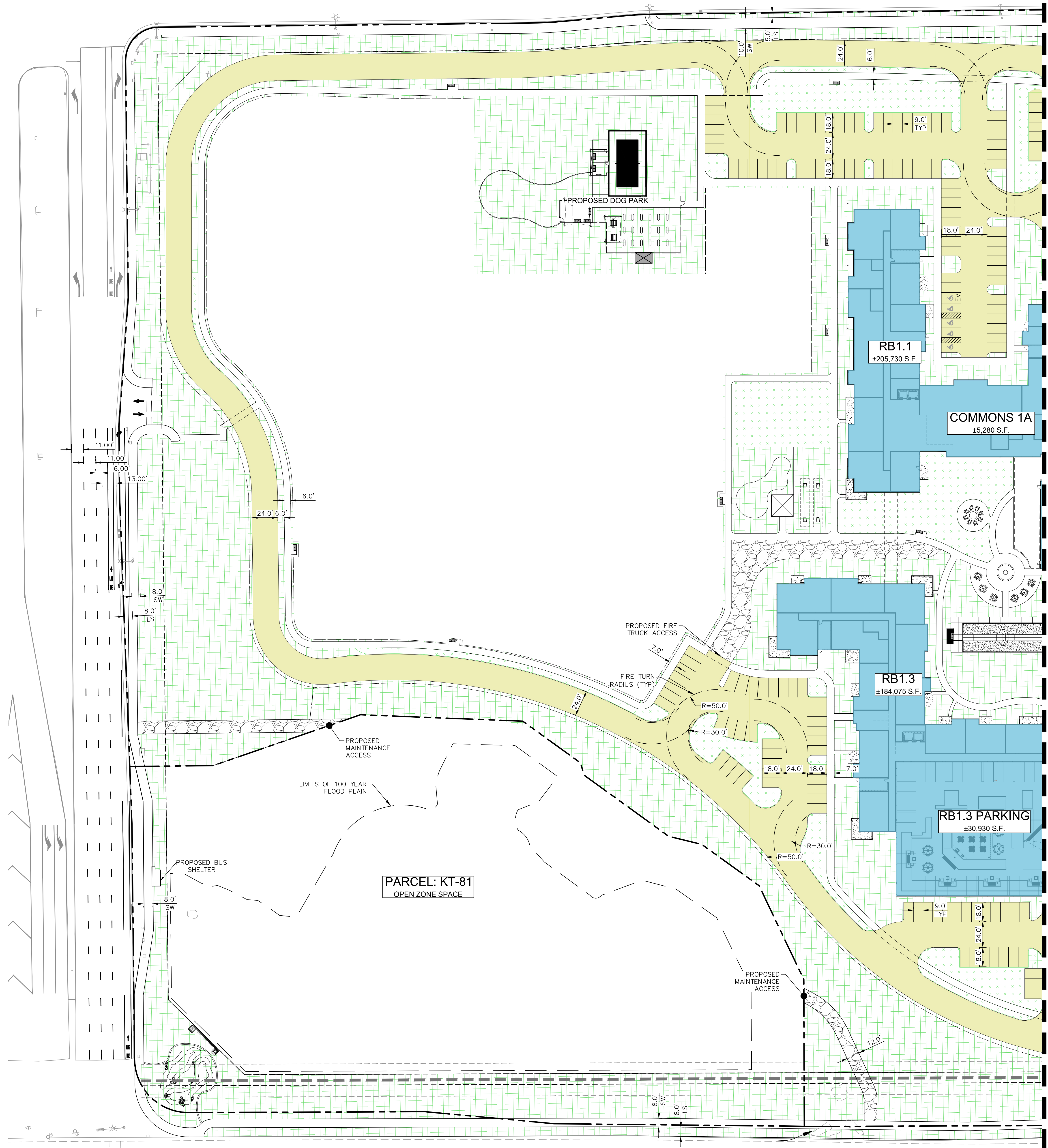

MATCHLINE - SEE SHEET SITE PLAN - EAST

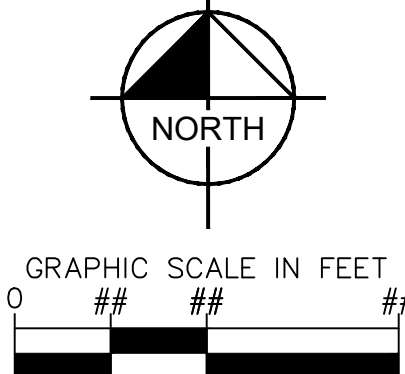

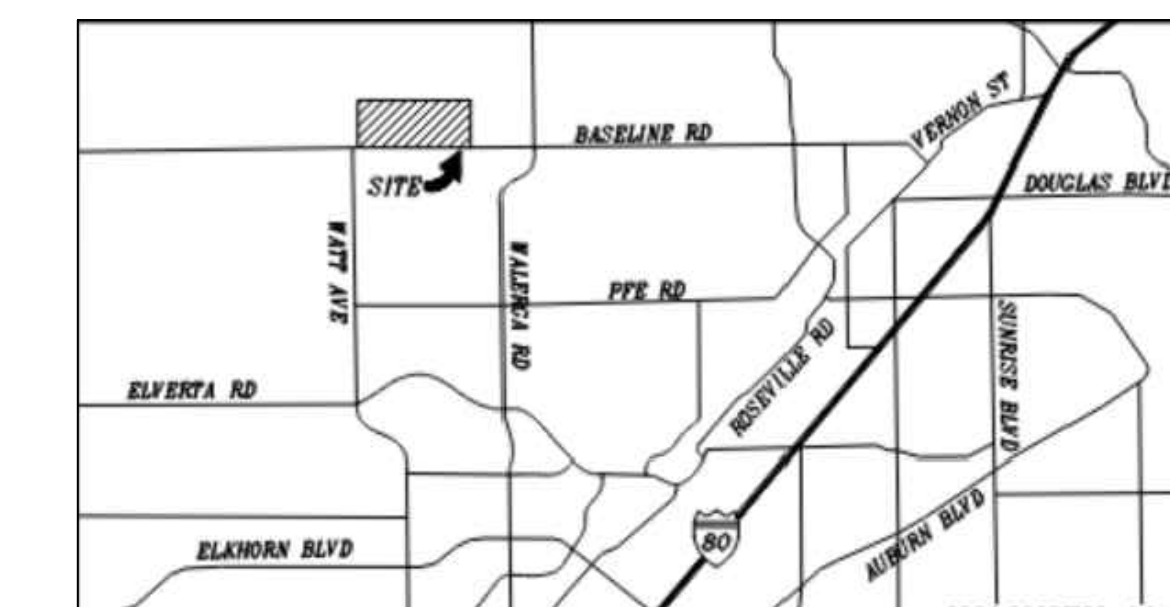





VICINITY MAP

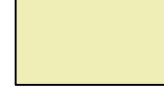
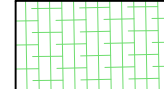

LEGEND

-  ASPHALT PAVEMENT
-  LANDSCAPE AREA
-  CONCRETE SIDEWALK
-  BUILDING AREA
-  FIRE TRUCK RADIUS (TYP 30' & 50')

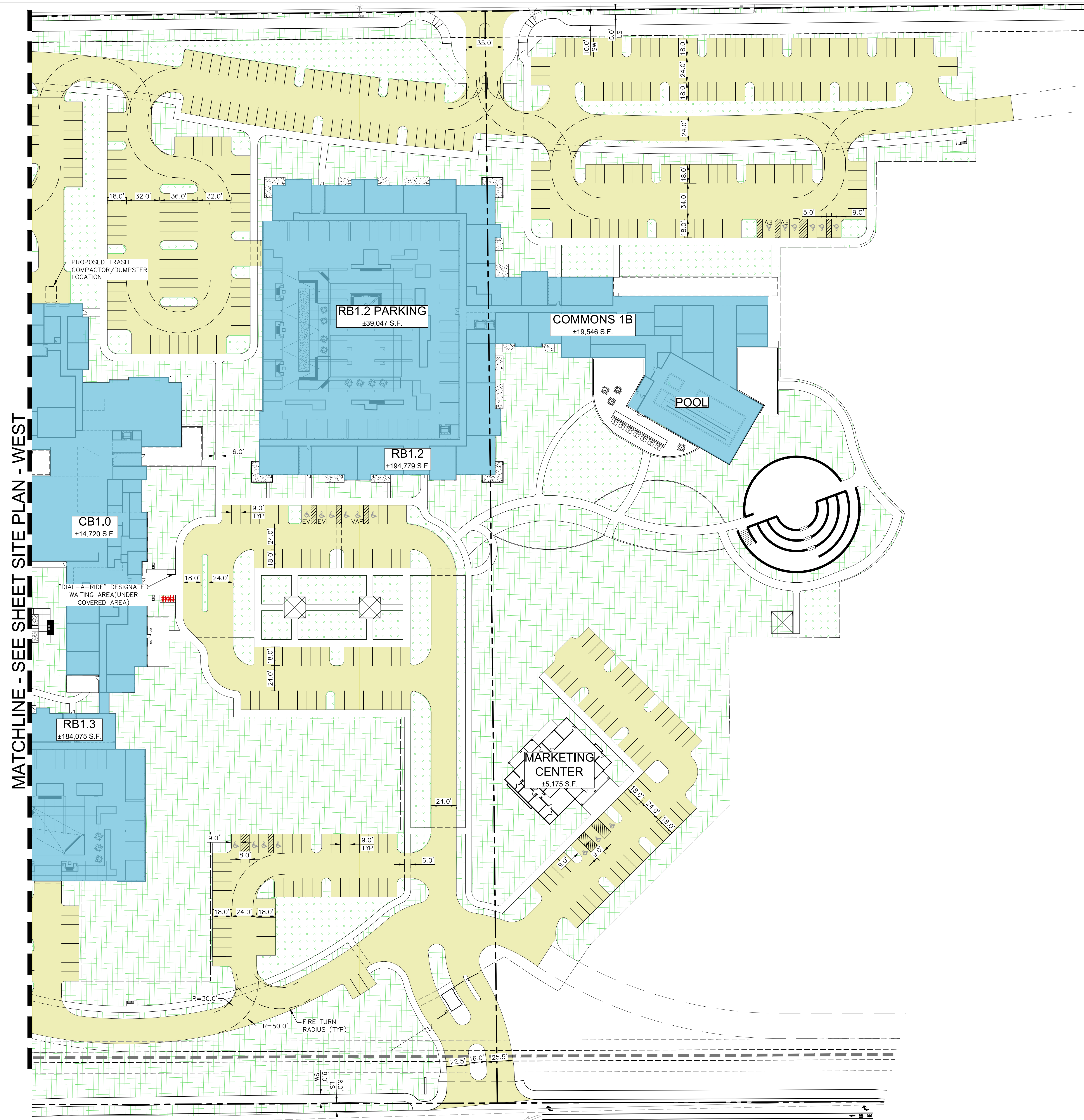

MATCHLINE - SEE SHEET SITE PLAN - WEST

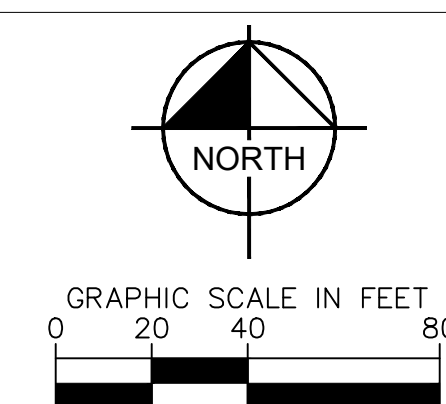

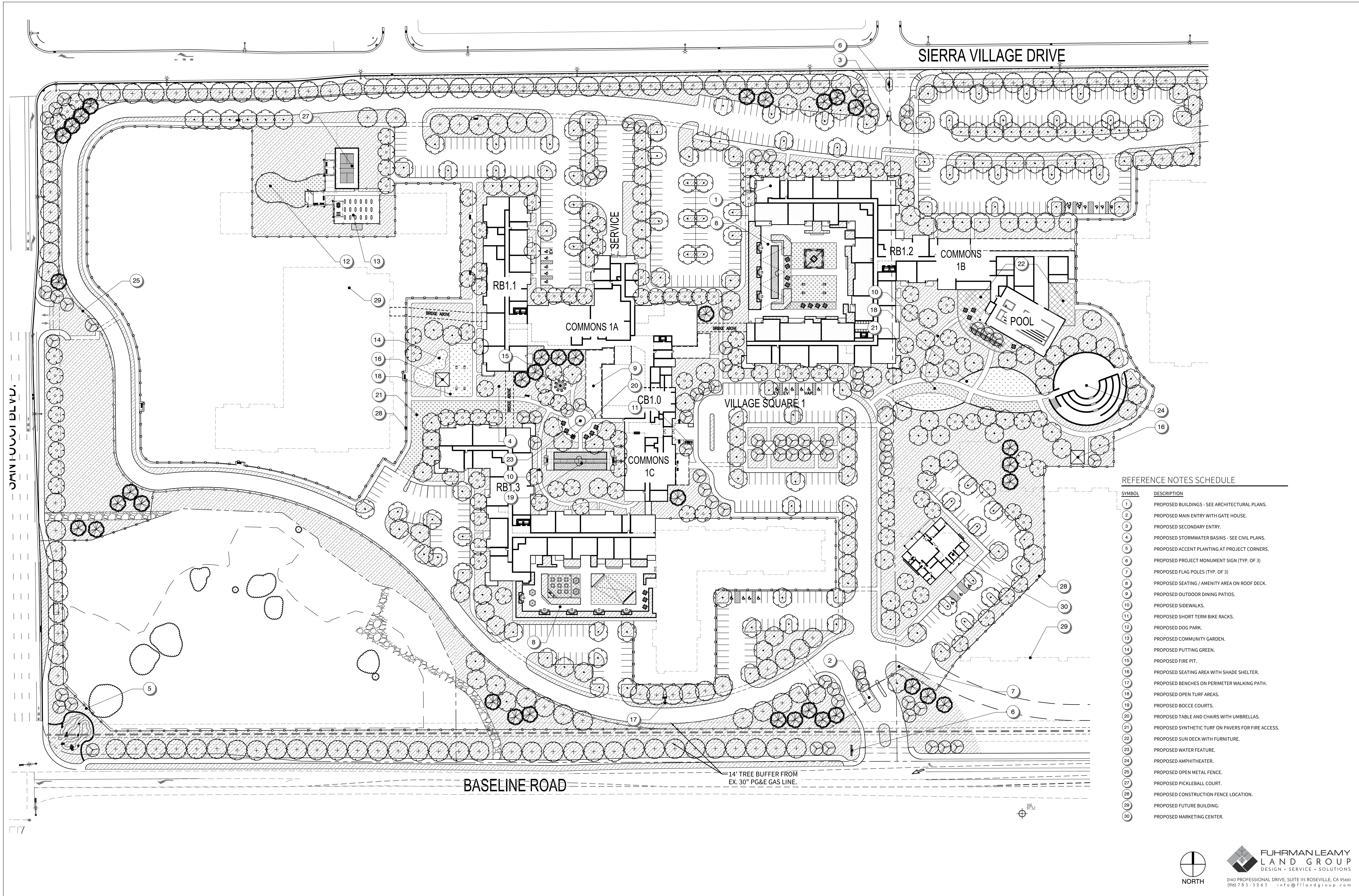

SIERRA VILLAGE DRIVE

JAIN LUVU BLVD.

BASELINE ROAD

14' TREE BUFFER FROM EX. 30" PG&E GAS LINE.

REFERENCE NOTES SCHEDULE

SYMBOL	DESCRIPTION
1	PROPOSED BUILDINGS - SEE ARCHITECTURAL PLANS.
2	PROPOSED MAIN ENTRY WITH GATE HOUSE.
3	PROPOSED SECONDARY ENTRY.
4	PROPOSED STORMWATER BASINS - SEE CIVIL PLANS.
5	PROPOSED ACCENT PLANTING AT PROJECT CORNERS.
6	PROPOSED PROJECT MONUMENT SIGN (TYP. OF 3)
7	PROPOSED FLAG POLES (TYP. OF 3)
8	PROPOSED SEATING / AMENITY AREA ON ROOF DECK.
9	PROPOSED OUTDOOR DINING PATIOS.
10	PROPOSED SIDEWALKS.
11	PROPOSED SHORT TERM BIKE RACKS.
12	PROPOSED DOG PARK.
13	PROPOSED COMMUNITY GARDEN.
14	PROPOSED PUTTING GREEN.
15	PROPOSED FIRE PIT.
16	PROPOSED SEATING AREA WITH SHADE SHELTER.
17	PROPOSED BENCHES ON PERIMETER WALKING PATH.
18	PROPOSED OPEN TURF AREAS.
19	PROPOSED BOCCIE COURTS.
20	PROPOSED TABLE AND CHAIRS WITH UMBRELLAS.
21	PROPOSED SYNTHETIC TURF ON PAVERS FOR FIRE ACCESS.
22	PROPOSED SUN DECK WITH FURNITURE.
23	PROPOSED WATER FEATURE.
24	PROPOSED AMPHITHEATER.
25	PROPOSED OPEN METAL FENCE.
27	PROPOSED PICKLEBALL COURT.
28	PROPOSED CONSTRUCTION FENCE LOCATION.
29	PROPOSED FUTURE BUILDING.
30	PROPOSED MARKETING CENTER.



NORTH

FUHRMAN LEAMY LAND GROUP
 DESIGN · SERVICE · SOLUTIONS
 2140 PROFESSIONAL DRIVE, SUITE 115 ROSEVILLE, CA 95661
 (916) 783-5263 info@fllandgroup.com

SHADE STUDY CALCULATIONS

PROJECT: ERICKSON SENIOR LIVING 11.18.2022

PHASE 1 & 1A (STAGE 2)	STANDARD STALLS	COMPACT STALLS	HANDICAP STALLS	TOTAL PAVED PARKING AREA:	TOTAL SHADE REQUIRED:	TOTAL SHADE PROVIDED:	TOTAL SHADE PERCENTAGE
	555	0	28	157,410	50%	90,874	58%

SYMBOL	PATTERN	QTY.	UNIT	IN S.F.	TOTAL S.F.
30 TO 35' TREES					
ACER R., PISTACHIA C., ULMUS C.	30-F	37	X	962	35,594
ZELKOVA S.	30-TQ	15	X	722	10,830
	30-H	70	X	481	33,670
	30-Q	30	X	240	7,200
25' TO 30' TREES					
ACER B., GINKGO B.	25-F	0	X	491	0
KOELREUTERIA P., ZELKOVA S.	25-TQ	0	X	369	0
	25-H	10	X	246	2,460
	25-Q	4	X	123	492
15' TO 20' TREES					
CERCIS O., LAGERSTROEMIA I.	15-F	0	X	314	0
MAGNOLIA G., CHITALPA T.	15-TQ	0	X	236	0
	15-H	4	X	157	628
	15-Q	0	X	79	0
TOTAL					90,874

CONCEPT PLANT SCHEDULE

- SHADE TREES**
 - ACER RUBRUM 'OCTOBER GLORY' / OCTOBER GLORY RED MAPLE (40'X35')
 - CELTIS OCCIDENTALIS / CHINESE HACKBERRY (40'X40')
 - PISTACHIA CHINENSIS / CHINESE PISTACHE (40'X40')
 - ZELKOVA SERRATA 'VILLAGE GREEN' / VILLAGE GREEN SAWLEAF ZELKOVA (50'X35')
- SCREEN TREES**
 - CEDRUS DEODARA / DEODAR CEDAR (60'X40")
 - PODOCARPUS GRACILIOR / FERN PINE (40'X20")
 - QUERCUS ILEX / HOLLY OAK (60'X40")
- ACCENT TREES**
 - CERCIS OCCIDENTALIS / WESTERN REDBUD (18'X18')
 - LAGERSTROEMIA INDICA X FAURIEI 'ARAPAHO' / RED CRAPE MYRTLE (25'X20')
 - MAGNOLIA GRANDIFLORA 'LITTLE GEM' / LITTLE GEM DWARF MAGNOLIA (25'X15')
 - X CHITALPA TASHKENTENSIS 'PINK DAWN' / PINK DAWN CHITALPA (30'X25')
- SUBORDINATE TREES**
 - ACER BUERGERIANUM / TRIDENT MAPLE (25'X25')
 - GINKGO BILOBA 'PRINCETON SENTRY' / MAIDENHAIR TREE (40'X20')
 - KOELREUTERIA PANICULATA / GOLDEN RAIN TREE (35'X30')
 - ZELKOVA SERRATA 'MUSASHINO' / MUSASHINO SAWLEAF ZELKOVA (40'X15')
- STREET TREE**
 - LIRIODENDRON TULIPIFERA / TULIP TREE (60'X40')
 - QUERCUS RUBRA / RED OAK (60'X45')
- SHRUB AREA**
 - ACACIA COGNATA 'ACCOG01' / COUSIN ITT LITTLE RIVER WATTLE (3'X5')
 - CALLISTEMON VIMINALIS 'LITTLE JOHN' / LITTLE JOHN WEeping BOTTLEBRUSH (3'X3')
 - CISTUS X PURPUREUS / ORCHID ROCKROSE (4'X4')
 - DIANELLA TASMANICA 'VARIGATA' / VARIGATED FLAX LILY (4'X3')
 - DIETES BICOLOR / FORTNIGHT LILY (3'X3')
 - ELAEAGARPUS DECIPENS 'MONPROUD' / JAPANESE BLUEBERRY TREE DWARF (10'X8')
 - GREVILLEA X 'NOELLI' / NOEL GREVILLEA (6'X5')
 - HYPERICUM X MOSERANUM / GOLD FLOWER (3'X3')
 - MUHLENBERGIA RIGENS / DEER GRASS (4'X4')
 - NANDINA DOMESTICA 'GULF STREAM' TM / GULF STREAM HEAVENLY BAMBOO (4'X2')
 - PRUNUS CAROLINIANA 'MONUS' TM / BRIGHT 'N TIGHT LAUREL CHERRY (8'X6')
 - RHAMNUS CALIFORNICA 'MOUND SAN BRUNO' / CALIFORNIA COFFEEBERRY (5'X8')
 - RHAPHIOLEPIS UMBELLATA / YEDDA HAWTHORN (5'X5')
 - RHAPHIOLEPIS UMBELLATA 'MINOR' / DWARF YEDDA HAWTHORNE (4'X4')
- GROUND COVER AREA**
 - ARCTOSTAPHYLOS X 'EMERALD CARPET' / EMERALD CARPET MANZANITA (12"X5')
 - COPROSMA KIRKII 'VERDE VISTA' / VERDE VISTA CREEPING COPROSMA (3'X6')
 - COTONEASTER DAMMERI 'LOWFAST' / LOWFAST BEARBERRY COTONEASTER (8"X6')
 - LOMANDRA LONGIFOLIA 'BREEZE' / BREEZE MAT RUSH (3'X3')
 - TEUCRIUM X LUCIDRYS PROSTRATUM / GERMANDER (6"X3')
- TURF AREA**
 - TURF SOD BOLERO PLUS / FESCUE BLEND
- TURF - SYNTHETIC**

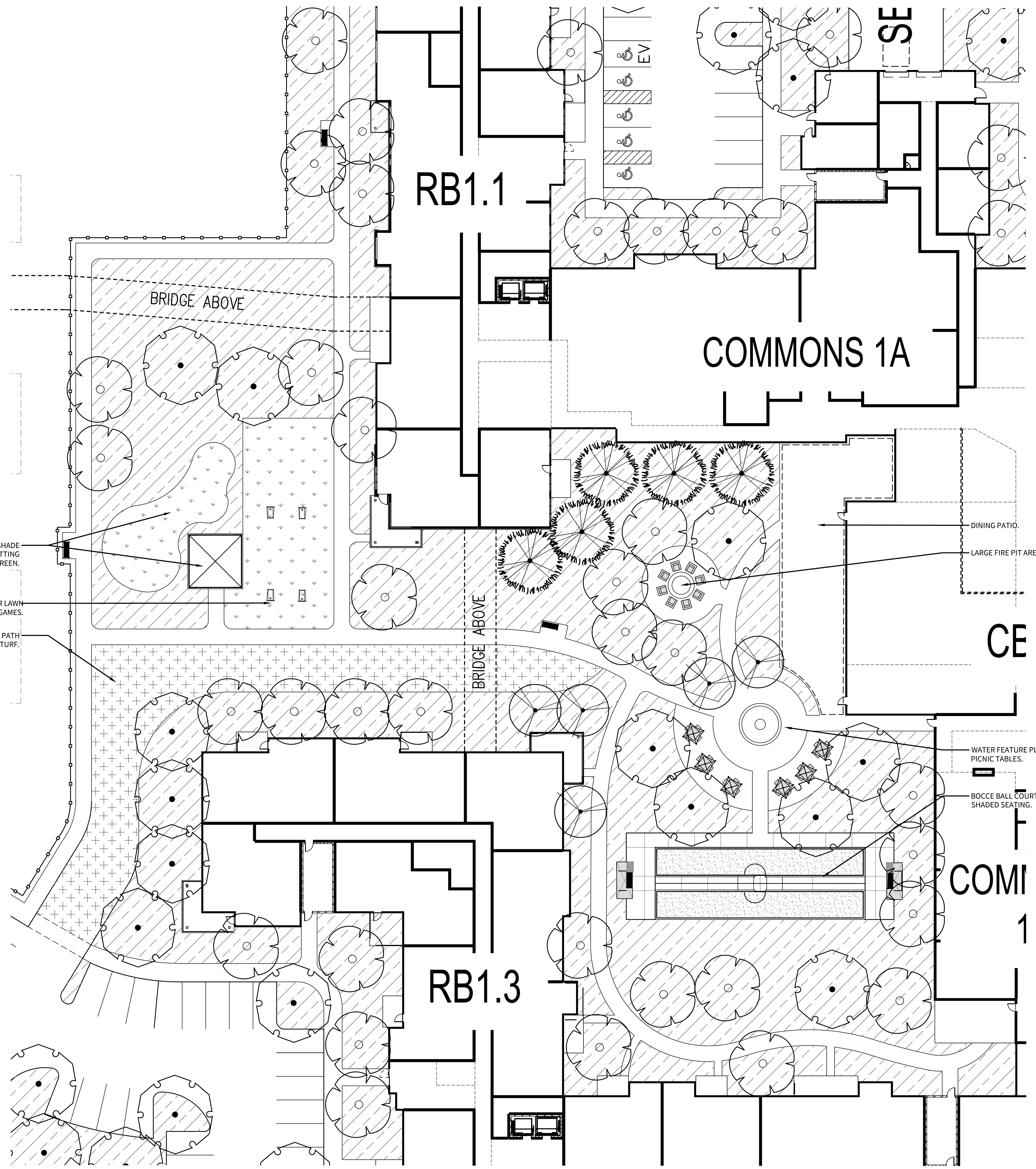

A COMMONS 1A & 1C COURTYARD
1" = 20'

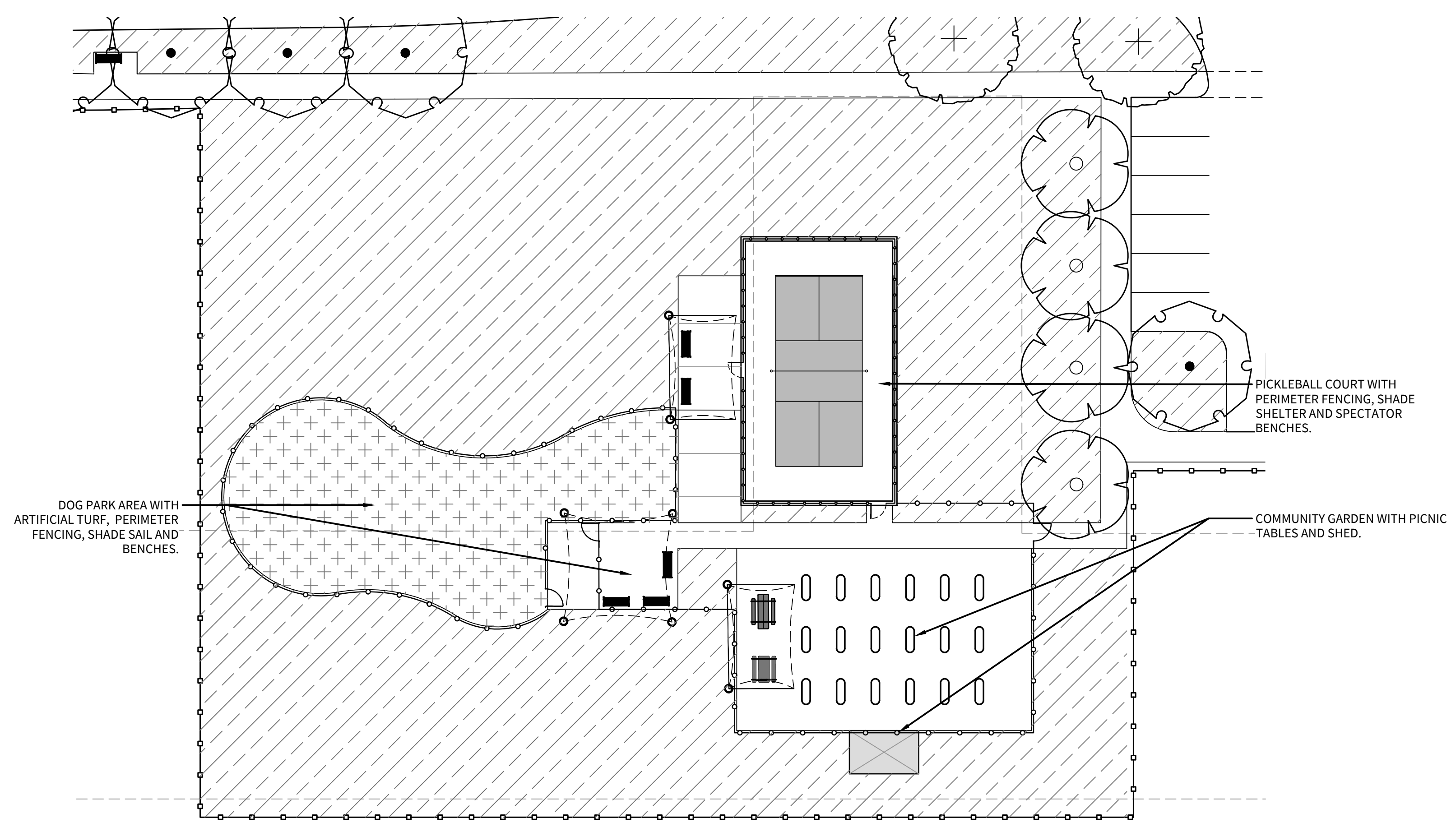

B PICKLEBALL, DOG PARK & COMMUNITY GARDEN
1" = 20'

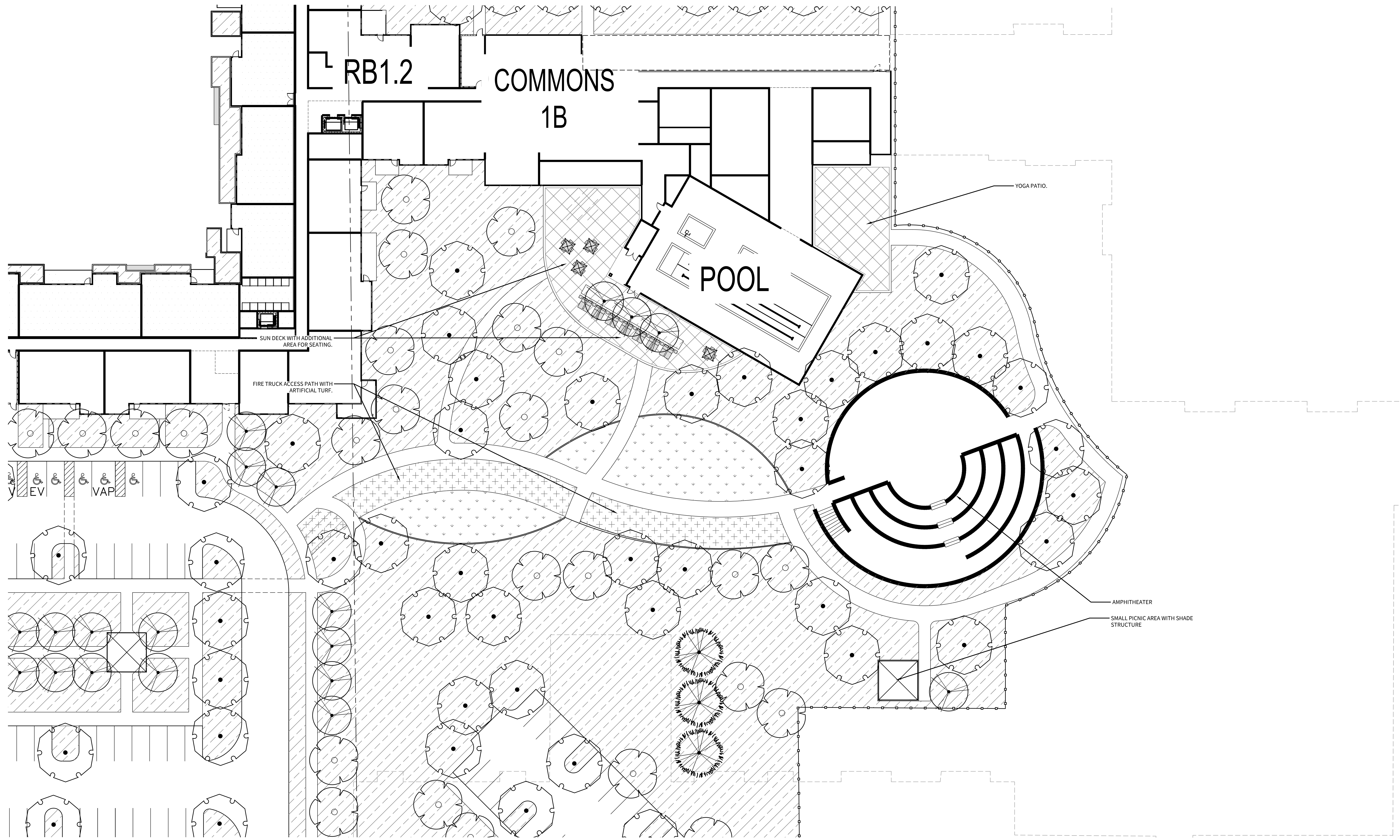

A COMMONS 1B COURTYARD
1" = 20'

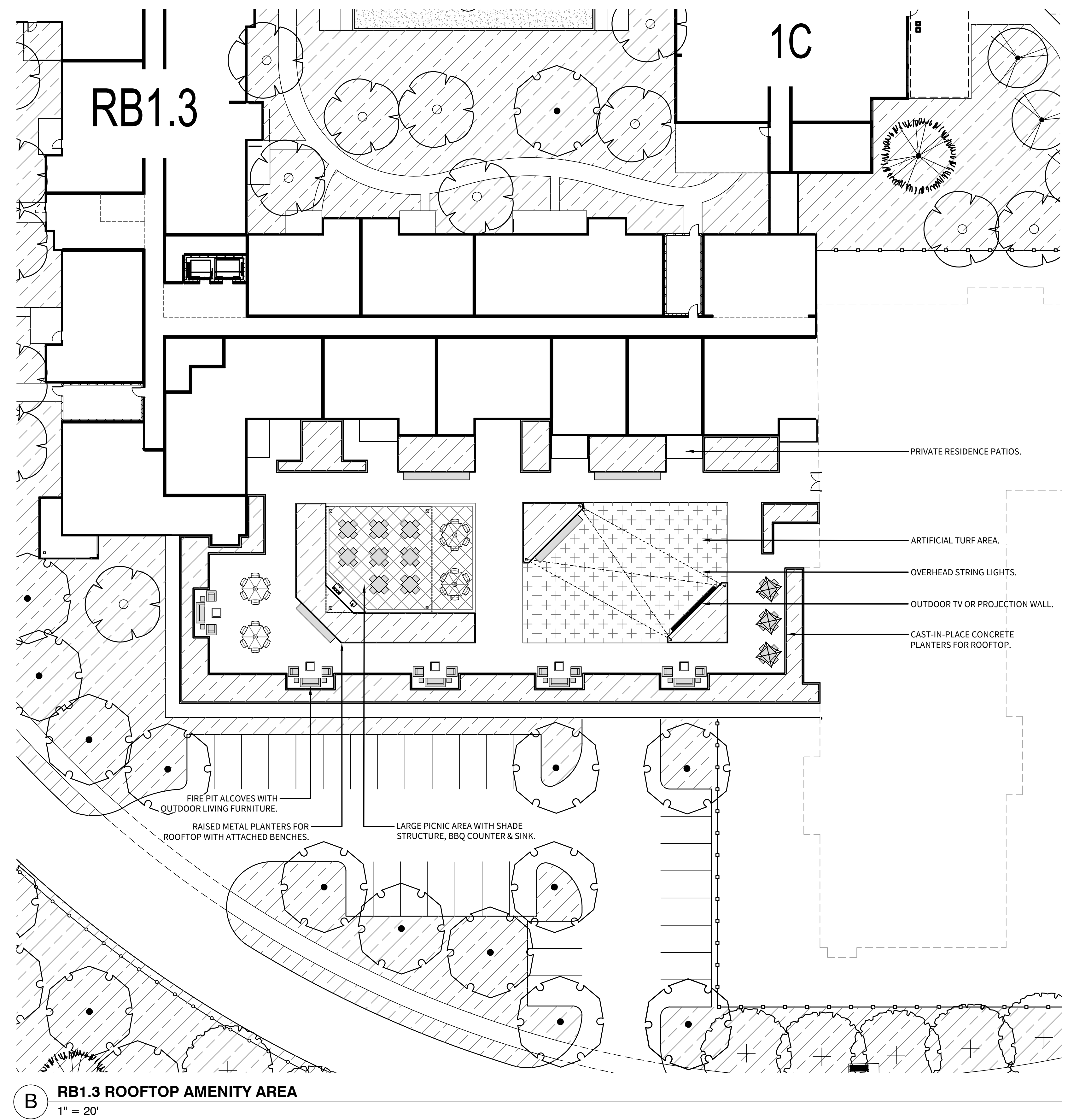
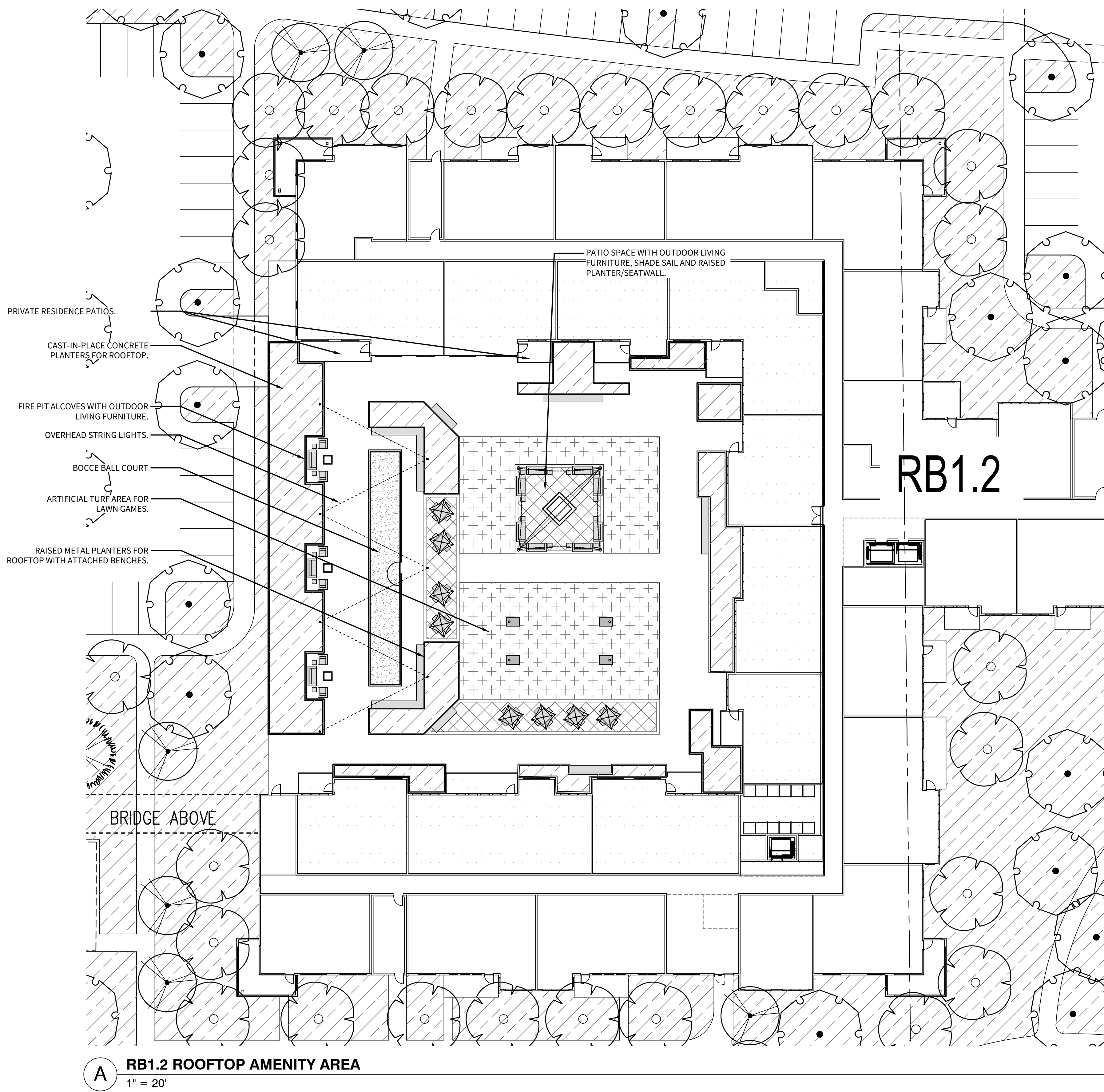



RB1.1 - SOUTH ELEVATION 01



RB1.1 - EAST ELEVATION 01



RB1.1 - SOUTH ELEVATION 02

RB1.1 ELEVATIONS

ERICKSON LIVING - SIERRA VISTA

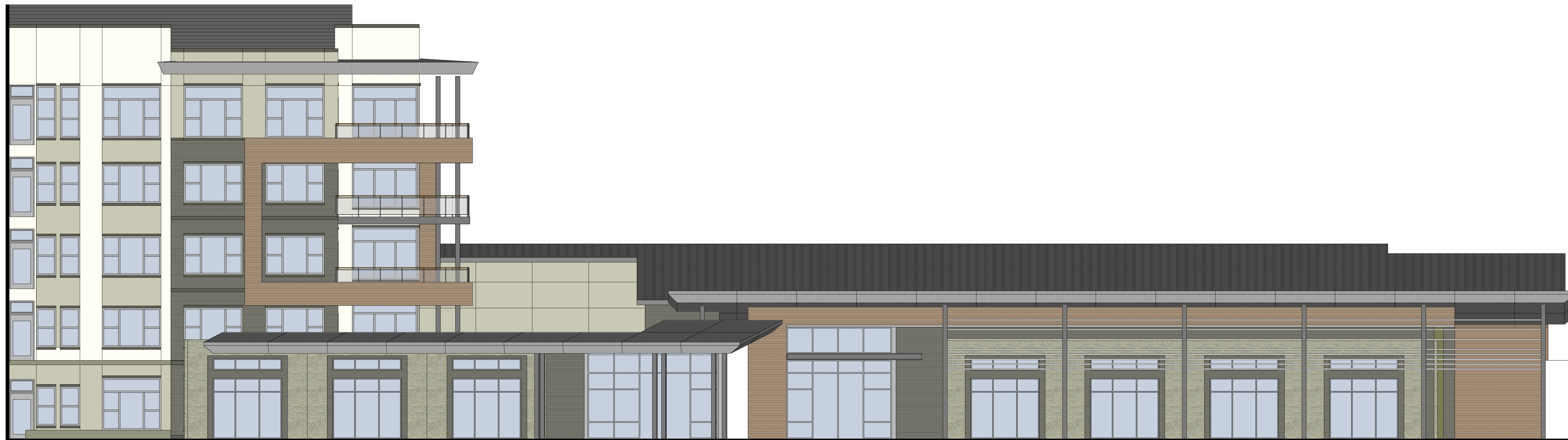

CB1.0 & RB1.1 - WEST ELEVATION 01



RB1.1 - SOUTH ELEVATION 03



CB1.0 & RB1.1 - EAST ELEVATION 01



RB1.1 - SOUTH ELEVATION 04

RB1.1 ELEVATIONS

ERICKSON LIVING - SIERRA VISTA



RB1.1 - EAST ELEVATION 02



RB1.1 - NORTH ELEVATION 01



RB1.1 - EAST ELEVATION 03



RB1.1 - NORTH ELEVATION 02



RB1.1 - WEST ELEVATION 02



RB1.1 - NORTH ELEVATION 03



RB1.1 - EAST ELEVATION 04



RB1.1 - NORTH ELEVATION 04



RB1.1 - WEST ELEVATION 04

RB1.1 VELEVATIONS

ERICKSON LIVING - SIERRA VISTA



O1 / SOUTH ELEVATION
1/8" = 1'



O2 / EAST ELEVATION
1/8" = 1'

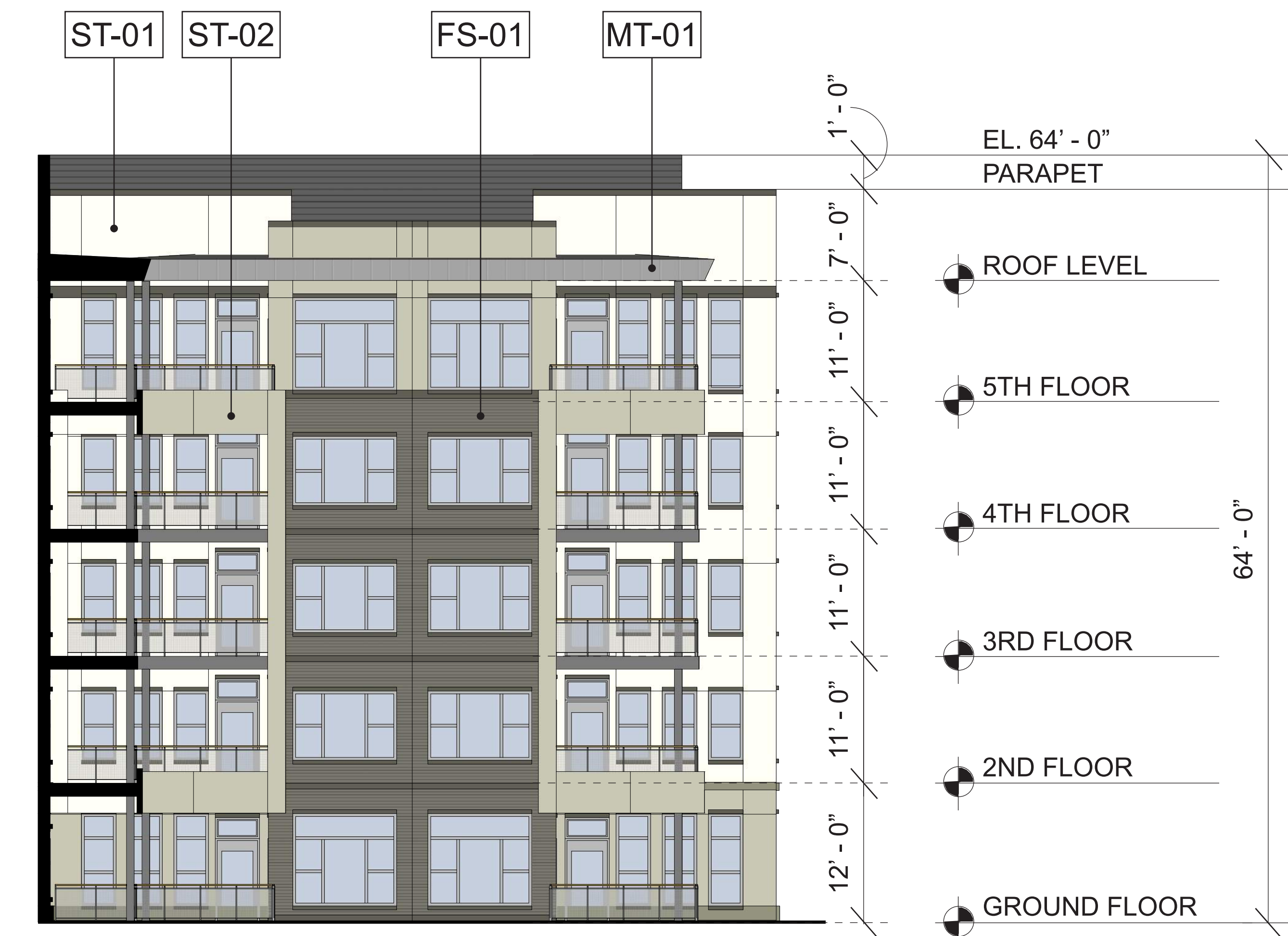

O3 / SOUTH ELEVATION
1/8" = 1'

EXTERIOR ELEVATIONS - RB1.2

ERICKSON SENIOR LIVING ROSEVILLE



RB1.2 - EAST ELEVATION 02



RB1.2 - NORTH ELEVATION 01



RB1.2 - EAST ELEVATION 03



RB1.2 - NORTH ELEVATION 02

RB1.2 ELEVATIONS

ERICKSON LIVING - SIERRA VISTA



RB1.2 - WEST ELEVATION 01



RB1.2 - SOUTH ELEVATION 03

RB1.2 ELEVATIONS

ERICKSON LIVING - SIERRA VISTA



RB1.2 - WEST ELEVATION 02



RB1.2 - NORTH ELEVATION 03



RB1.2 - WEST ELEVATION 03

RB1.2 ELEVATIONS

ERICKSON LIVING - SIERRA VISTA



RB1.3 - WEST ELEVATION 01



RB1.3 - SOUTH ELEVATION 01



RB1.3 - EAST ELEVATION 01



RB1.3 - SOUTH ELEVATION 02



RB1.3 - NORTH ELEVATION 01



RB1.3 - WEST ELEVATION 02



RB1.3 - SOUTH ELEVATION 03



RB1.3 - NORTH ELEVATION 02



RB1.3 - EAST ELEVATION 03

RB1.3 ELEVATIONS

ERICKSON LIVING - SIERRA VISTA

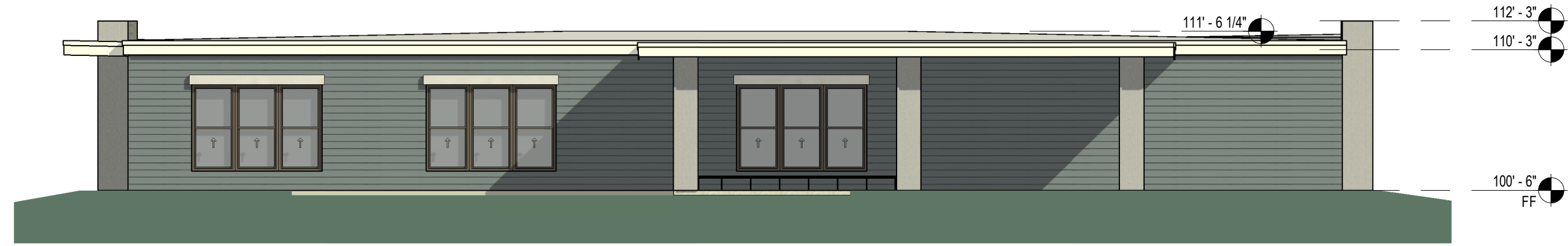

MARKETING CENTER NORTH ELEVATION

SCALE: 1/8" = 1'-0"

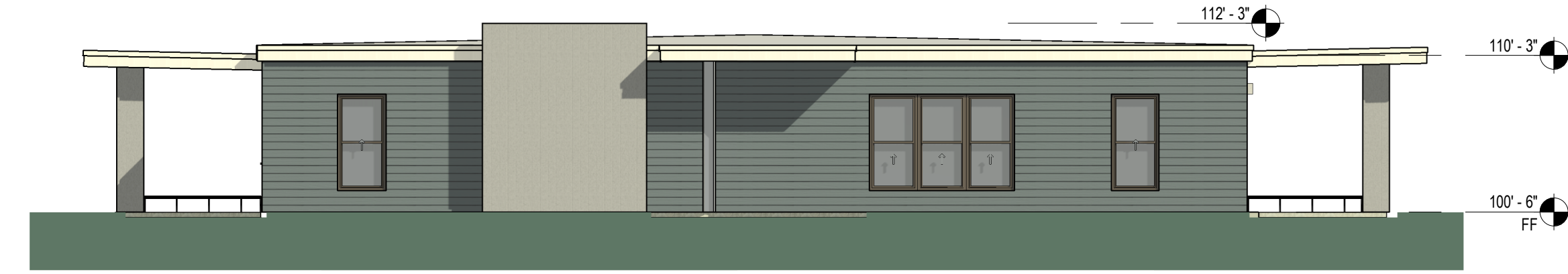

MARKETING CENTER EAST ELEVATION

SCALE: 1/8" = 1'-0"



MARKETING CENTER SOUTH ELEVATION

SCALE: 1/8" = 1'-0"

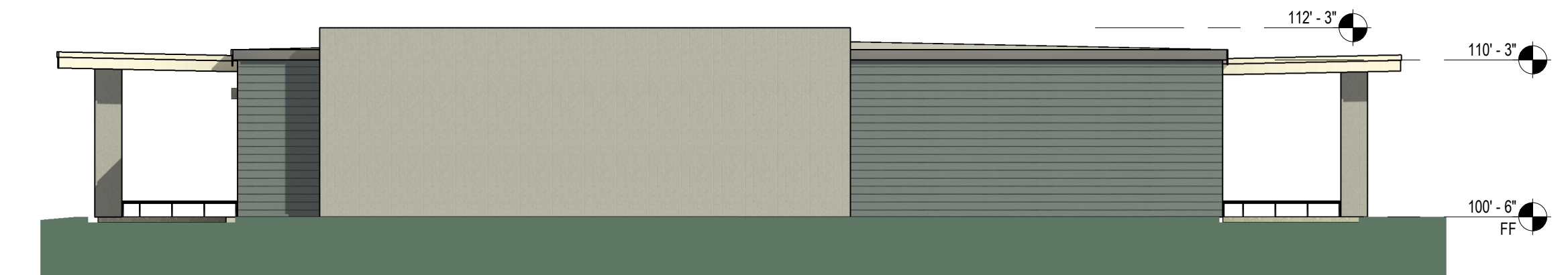

MARGETING CENTER WEST ELEVATION

SCALE: 1/8" = 1'-0"

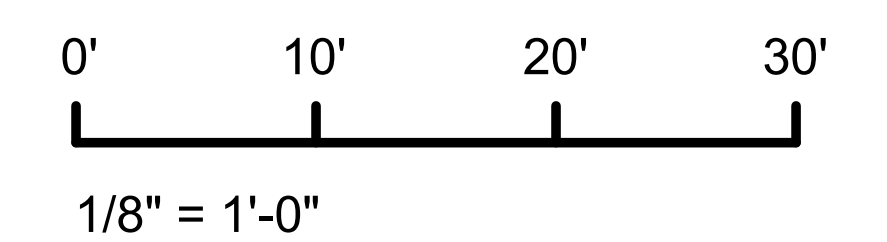
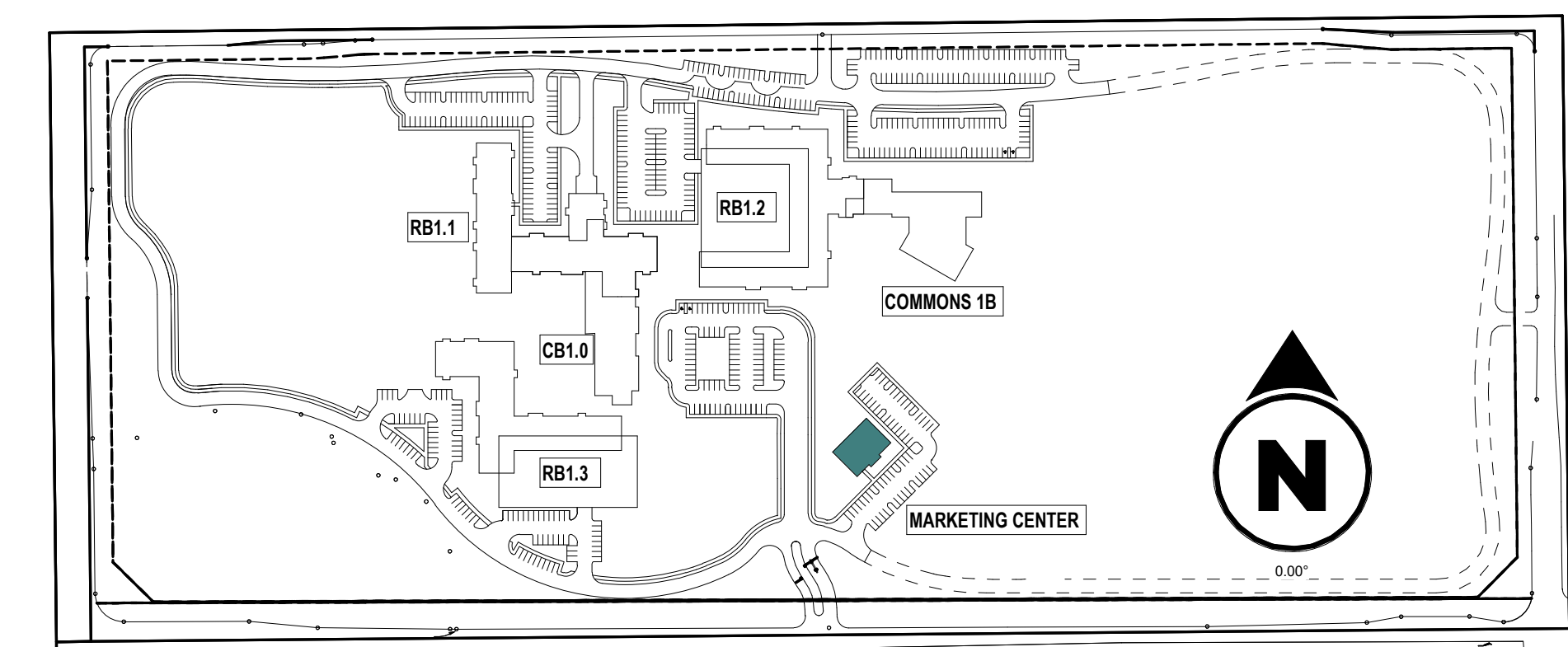

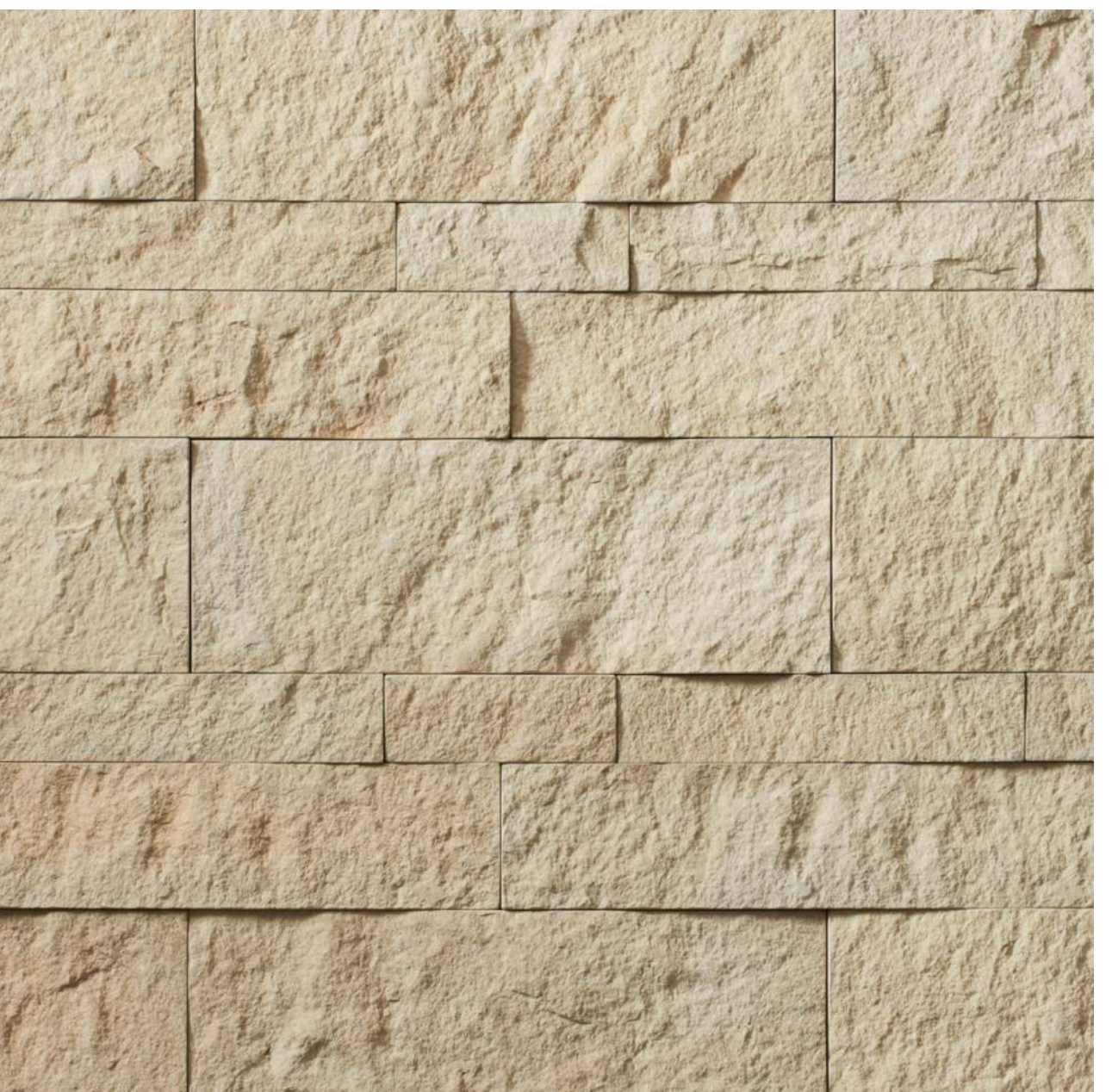

FS-01
PLANK LAP SIDING

FS-02
VERTICAL SIDING

MA-01
STONE

MA-02
BRICK

MA-03
BRICK

Designations Below
PAINTED STUCCO

TYPE: Fiber-cement planks

FINISH: Smooth texture
Manufacturer Primed for Paint
SW 6201 Thunderous or sim.



Window trim + accent trim:
SW 7020 Black Fox or sim.

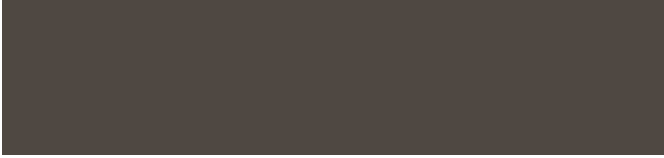

TYPE: Fiber-cement panel siding in vertical format
Window trim + accent trim to match

FINISH: Cedar texture
Painted
SW 2848 Roycroft Pewter or sim.



TYPE: Manufactured Stone Veneer
Corner units Required
Sill/Cap Stone where Required

FINISH: Hewn
Color as shown above or sim.

TYPE: Face Brick
Modular, Norman, or Utility
Cast Stone Sill/Cap where Required

FINISH: Velour
Color as shown above or sim.

TYPE: Face Brick
Modular, Norman, or Utility
Cast Stone Sill/Cap where Required

FINISH: Smooth
Color as shown above or sim.

TYPE: Two-coat assembly over metal lathe

FINISH: Smooth
SW 7004 Snowbound or sim.
ST-01

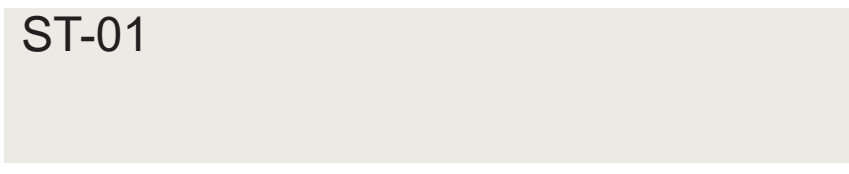

FINISH: Smooth
SW 7017 Dorian Gray or sim.
ST-02

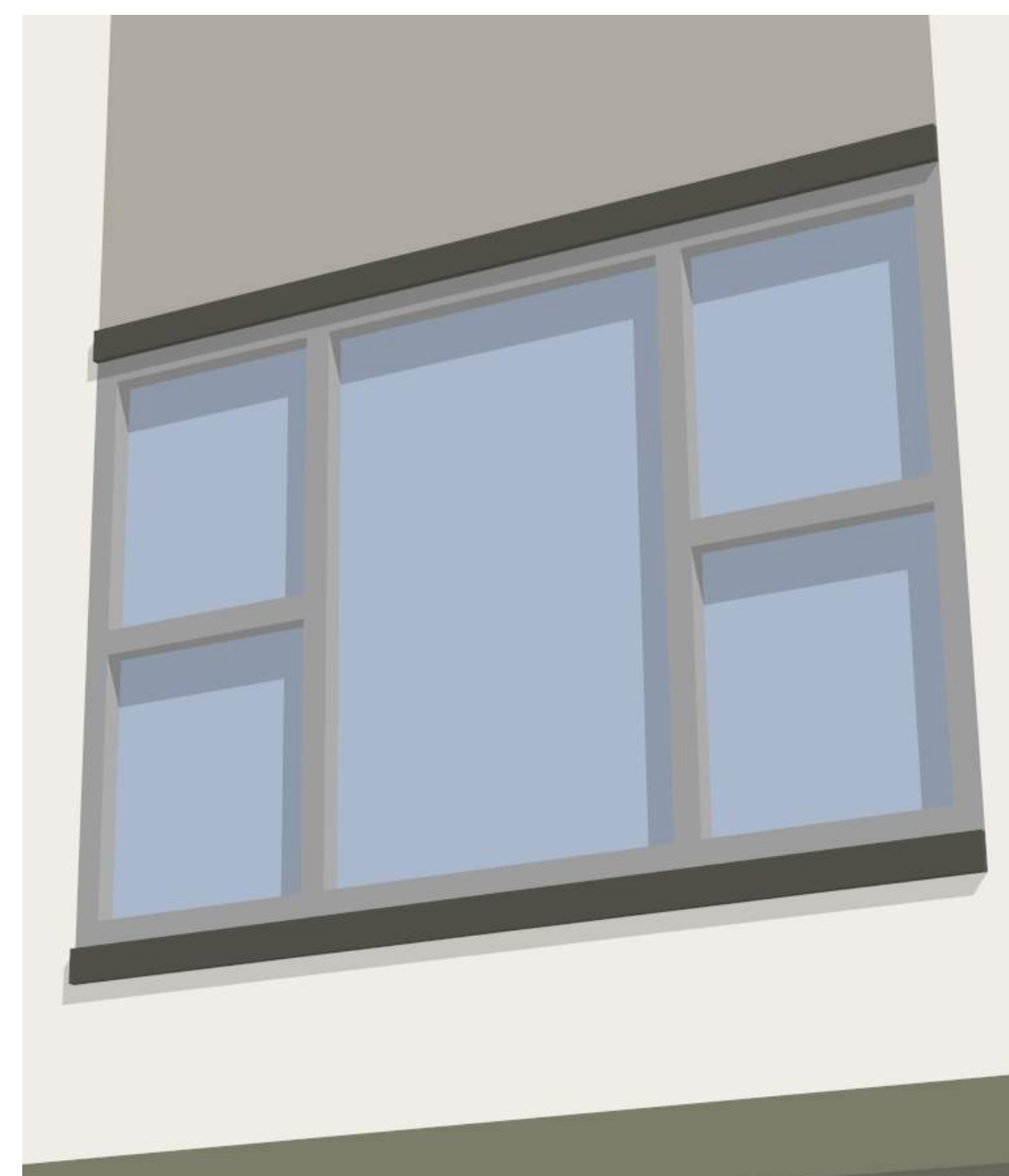
Designations Below
CANOPY MTL TRIM

MT-03
STANDING SEAM METAL ROOF

WD-01
CANOPY WOOD-LIKE SOFFIT

MR-01
PAINTED STEEL RAILING

MR-02
WELDED WIRE STEEL RAILING

W-01
FRAMED WINDOWS

W-02
STOREFRONT WINDOWS

TYPE: Fascia Panel System

FINISH: SILVER METALLIC OR SIM.
MT-01



Color Match SW 2848 Roycroft
Pewter
MT-02

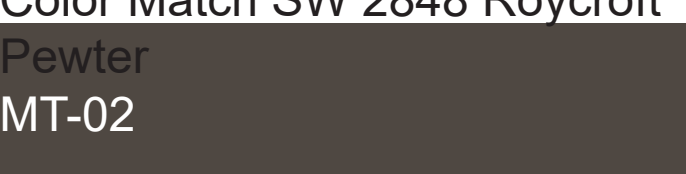

TYPE: Concealed Fastening System
2" Stand Off Sliding Clips
Matching color, gauge, and finish
for all trim and accessories

FINISH: Pewter or sim.



TYPE: Aluminum Fiber Cement board
or Sim.
Composite Panel System

FINISH: Western Red Cedar or Sim.



TYPE: High-temp baked enamel

FINISH: SW 2848 Roycroft Pewter or sim.



TYPE: High-temp baked enamel

FINISH: SW 2848 Roycroft Pewter or sim.



TYPE: Vinyl Framed Windows

FINISH: Medium gray exterior color
Prefinished interior color



TYPE: Aluminum mullion storefront glazing

FINISH: Clear Anodized



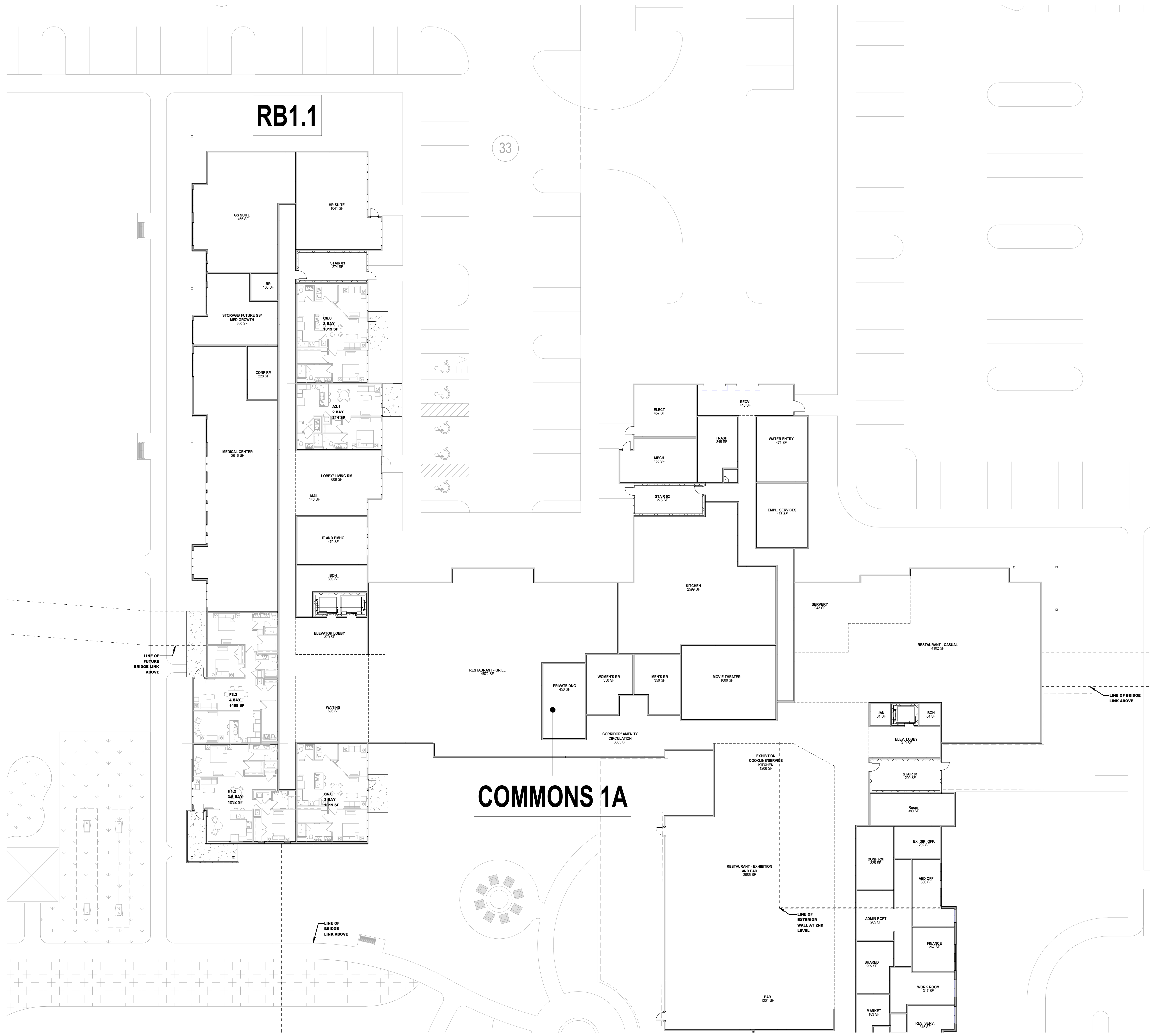

RB1.1

33

COMMONS 1A

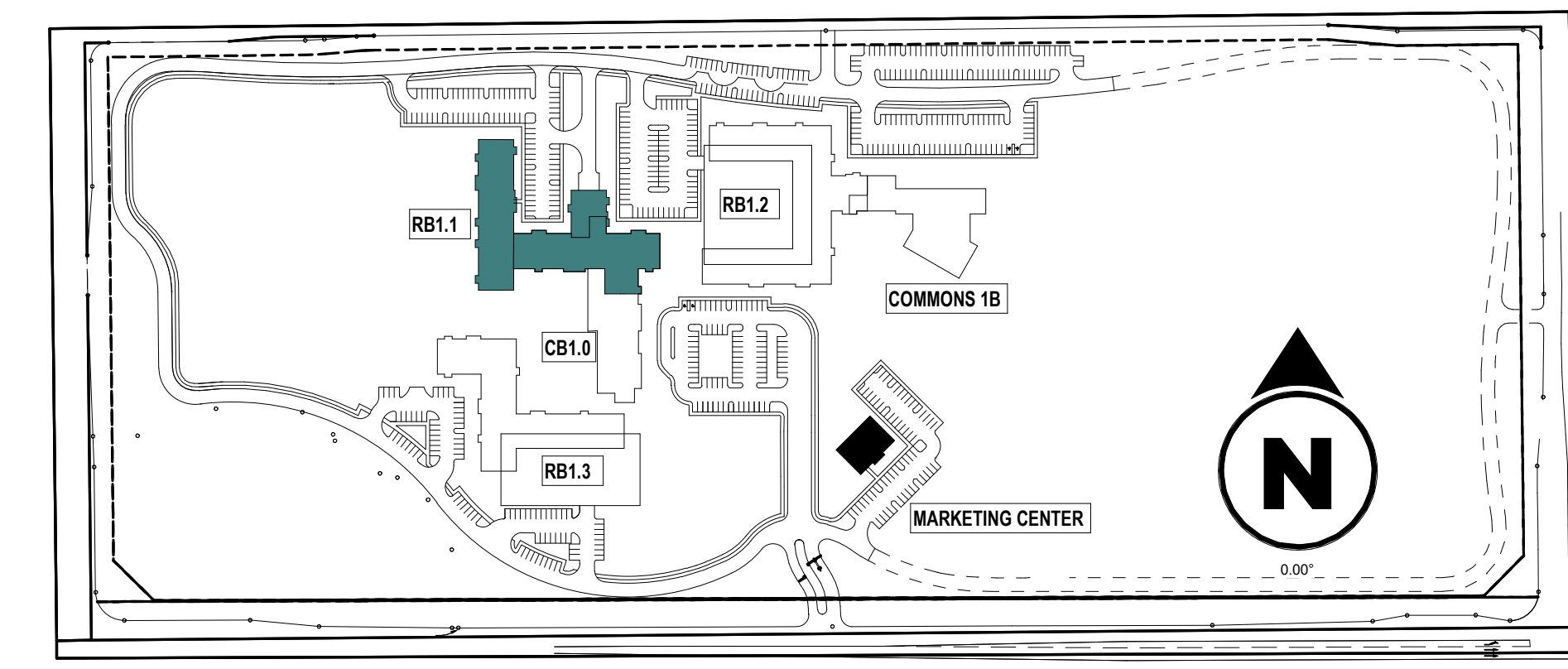

Erickson Senior Living Roseville
MPP Stage 2 Floor Plan - RB1.1 Ground Level

Sierra Vista, West Roseville, CA

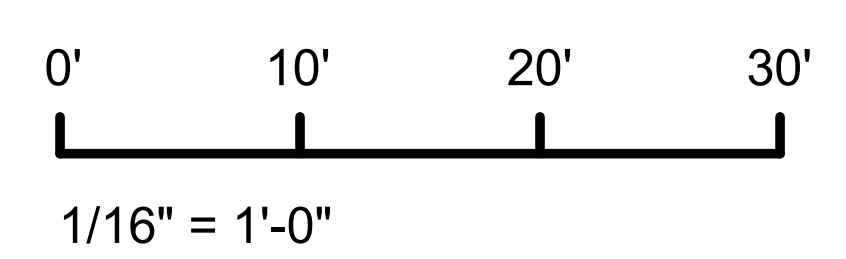



RB1.1

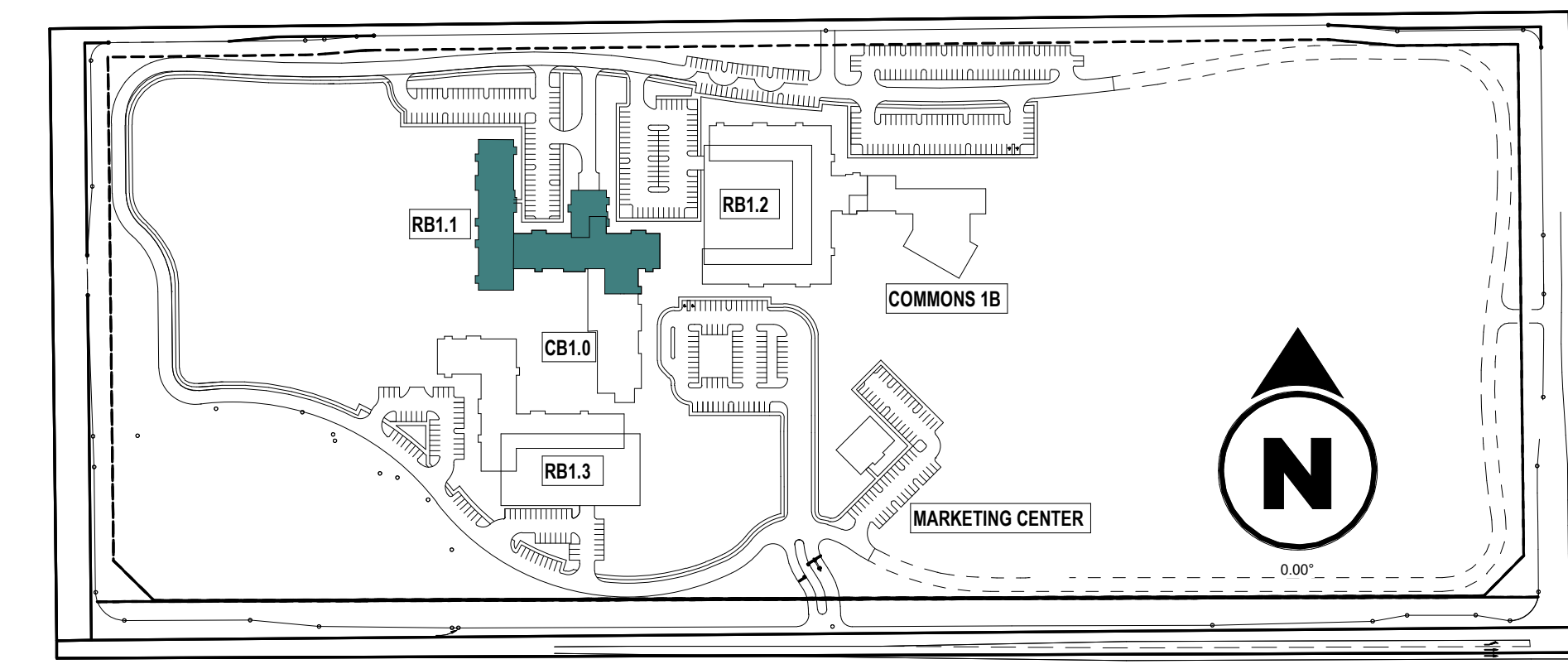

Erickson Senior Living Roseville
 MPP Stage 2 Floor Plan - RB1.1 Second Level
 Sierra Vista, West Roseville, CA

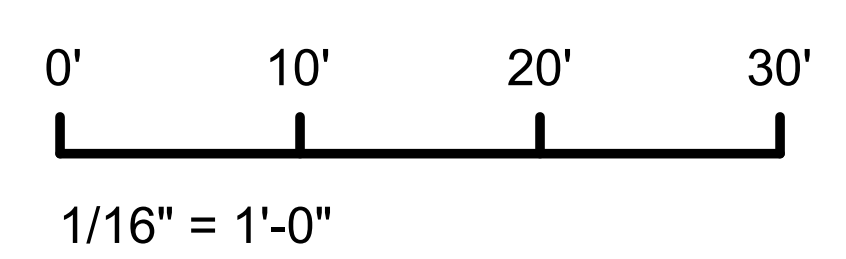

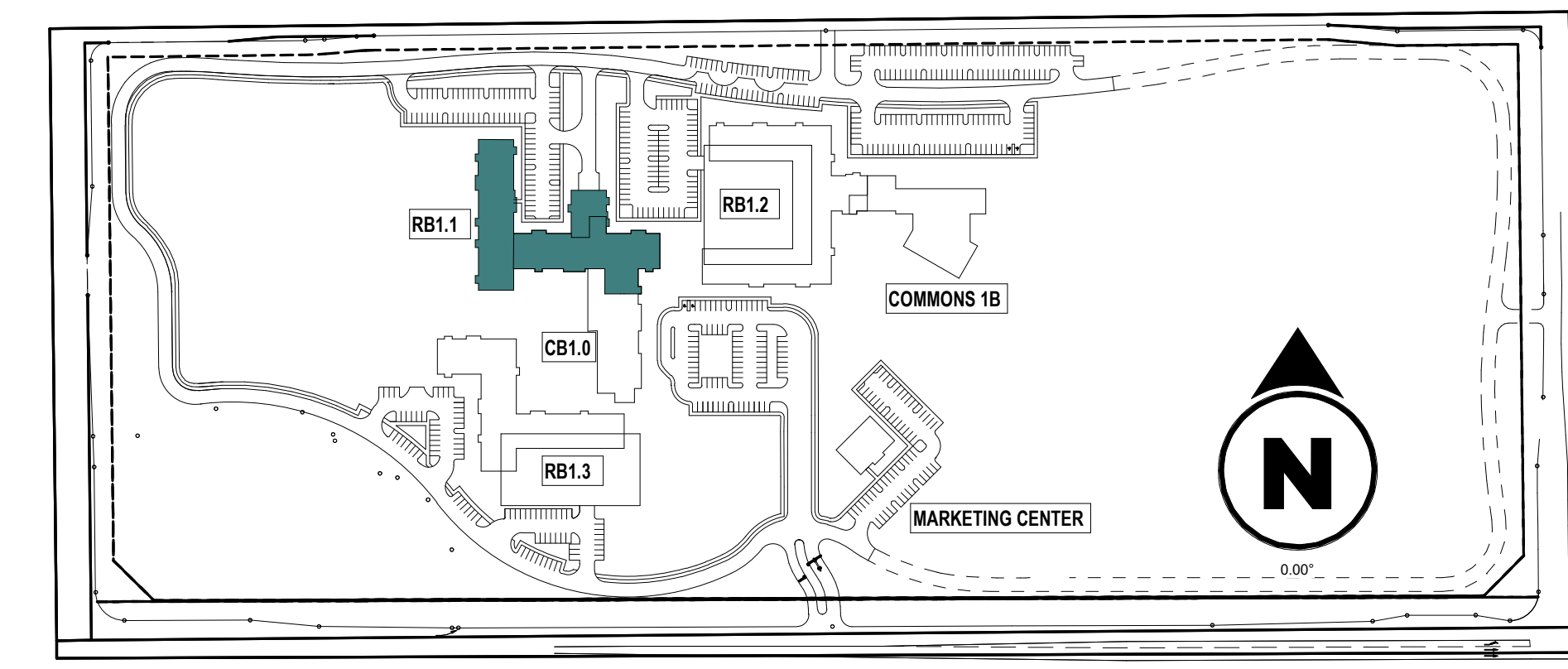

Erickson Senior Living Roseville
 MPP Stage 2 Floor Plan - RB1.1 Third-Fifth Level
 Sierra Vista, West Roseville, CA

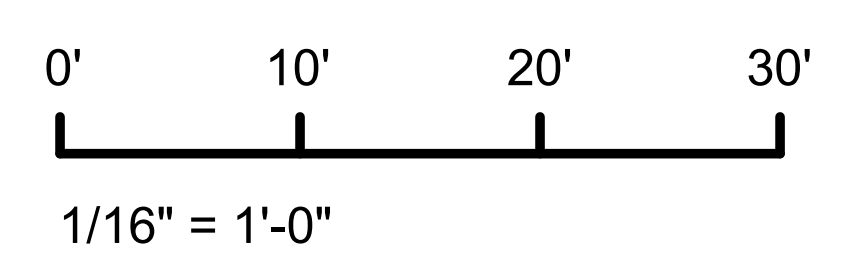

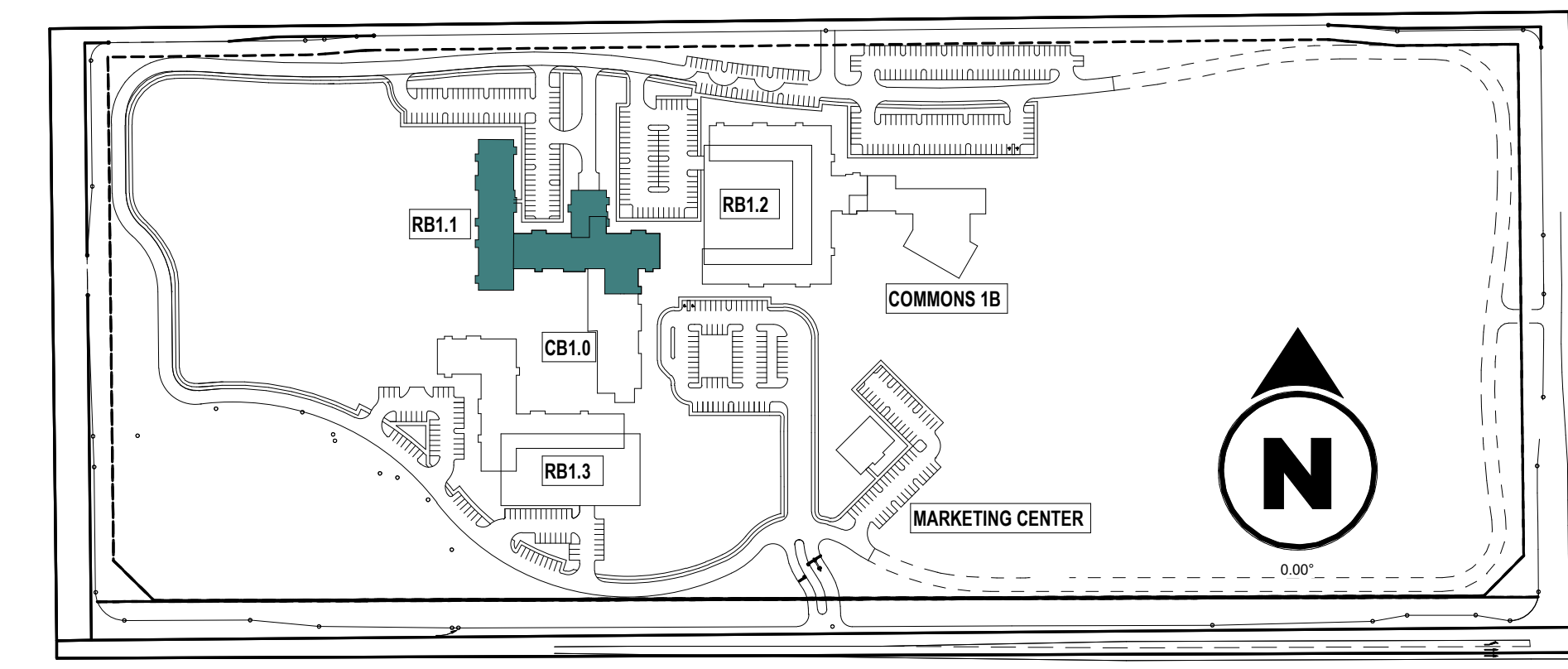
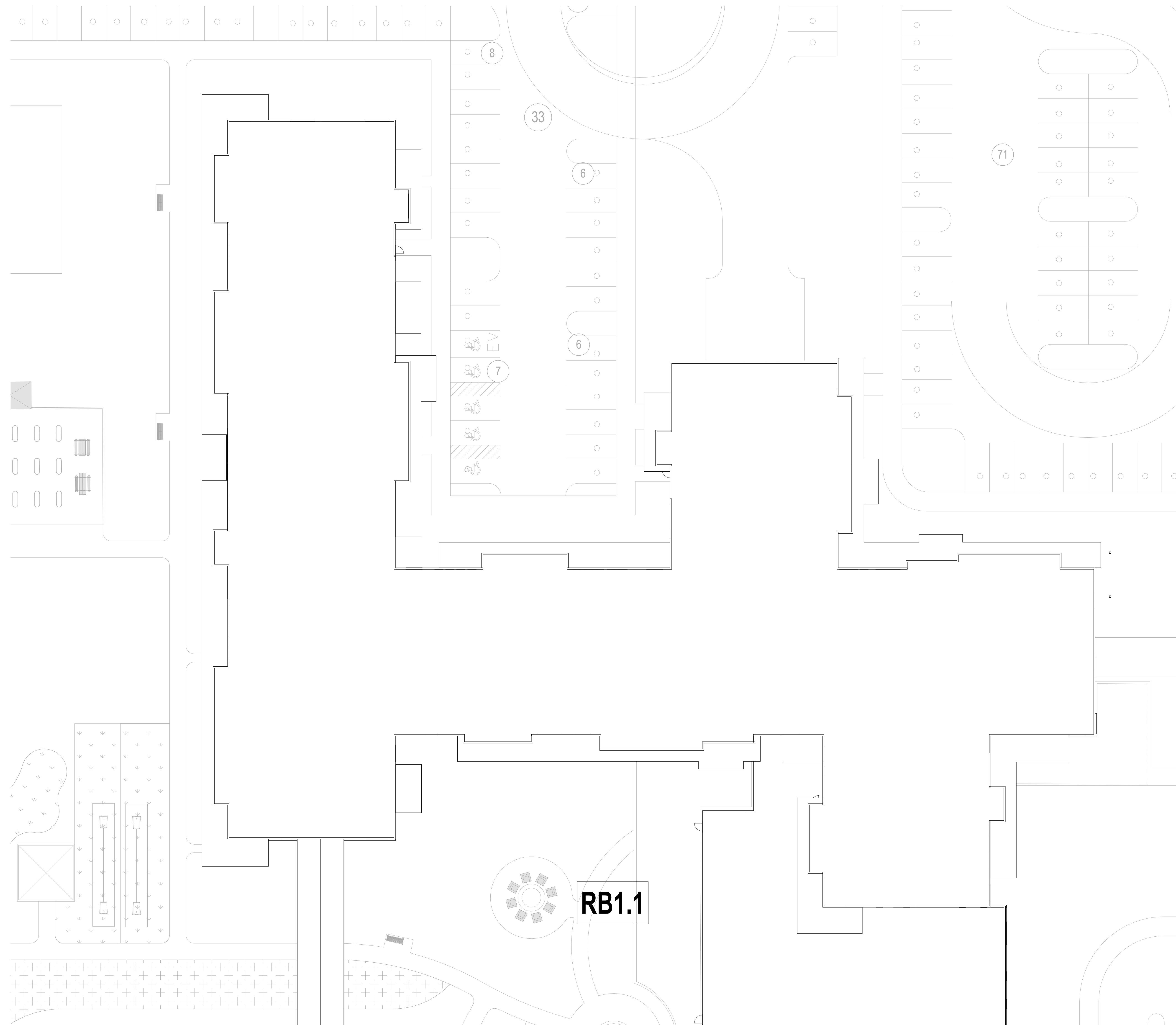

Erickson Senior Living Roseville
 MPP Stage 2 Roof Plan - RB1.1
 Sierra Vista, West Roseville, CA

0' 10' 20' 30'
 1/16" = 1'-0"



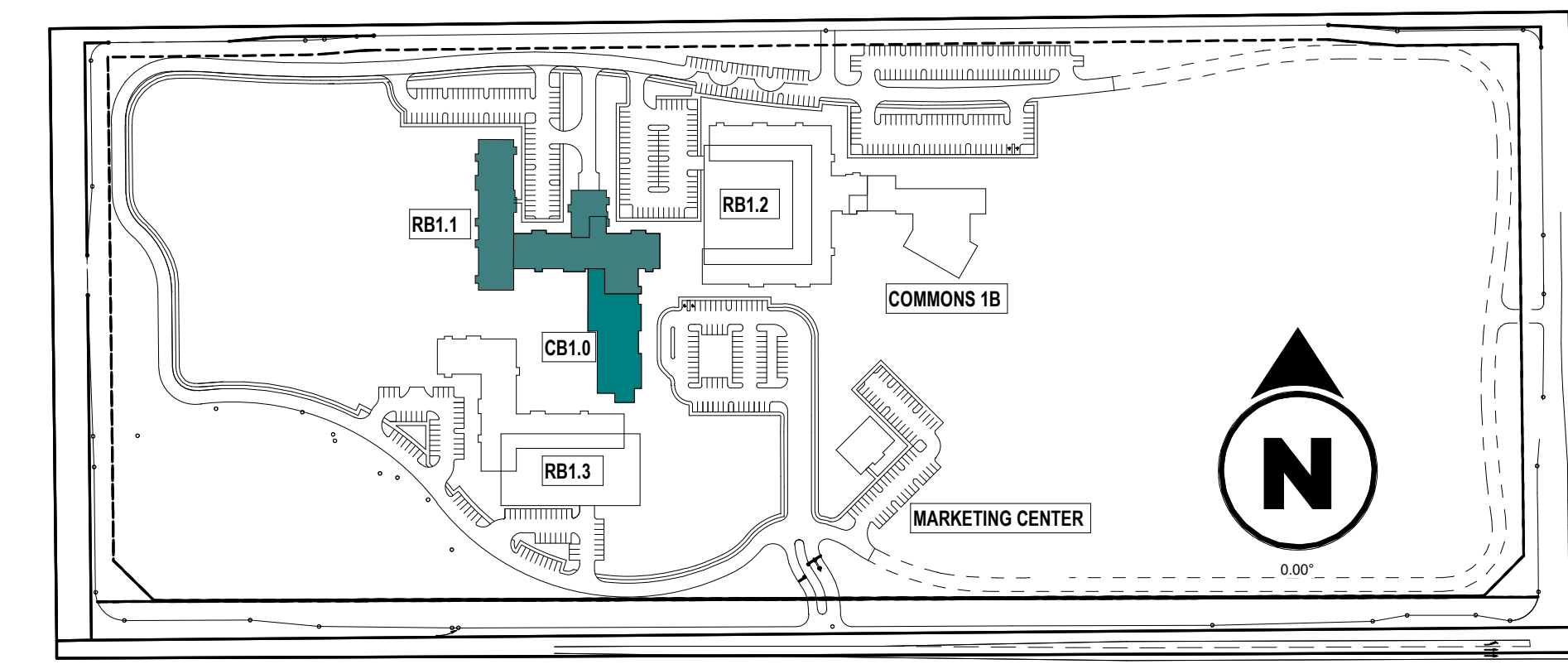
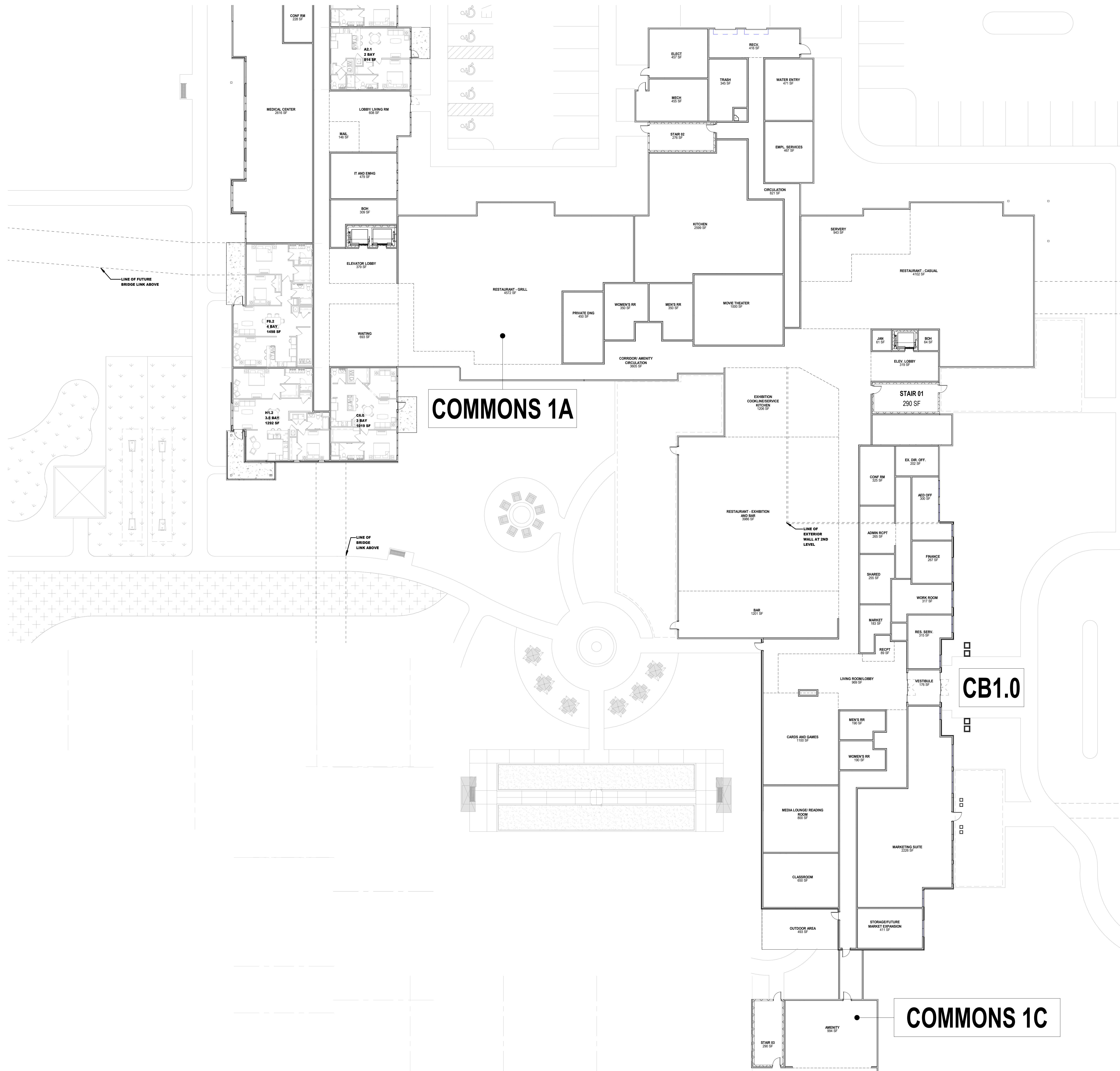

Erickson Senior Living Roseville
 MPP Stage 2 Amenity Floor Plan RB1.1, CB1.0, Commons 1A and 1C
 Sierra Vista, West Roseville, CA

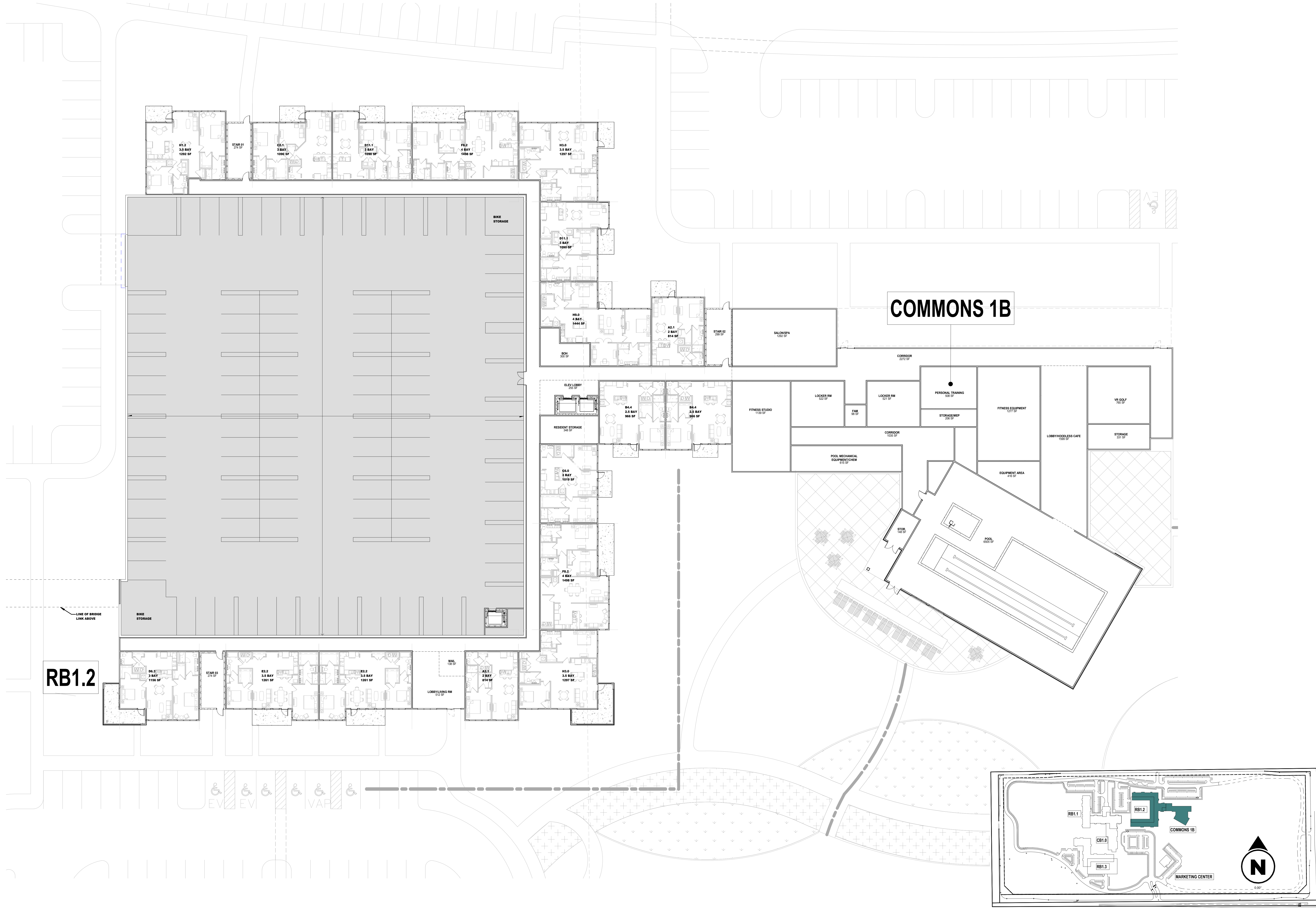

RB1.2

COMMONS 1B

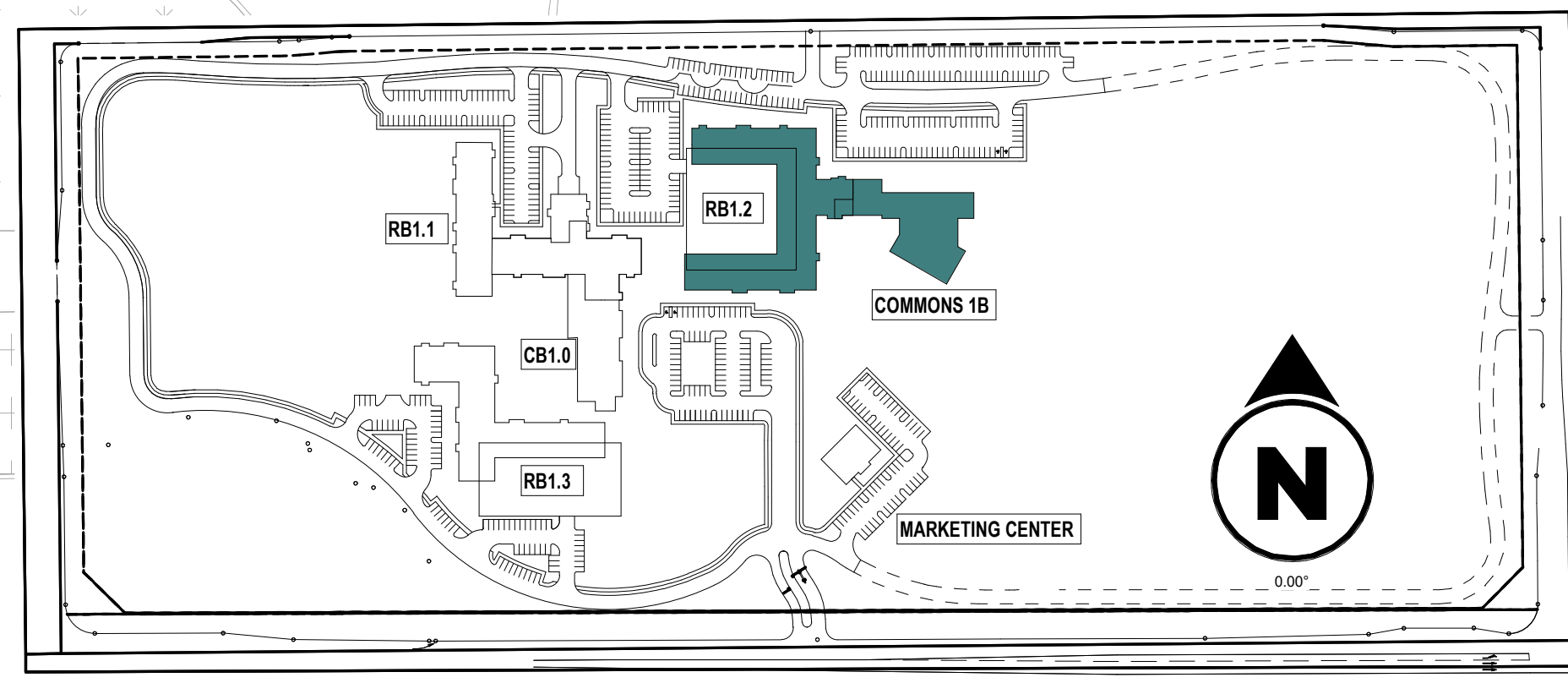

Erickson Senior Living Roseville

MPP Stage 2 Floor Plan - RB1.2 & Commons 1B Ground Level

Sierra Vista, West Roseville, CA

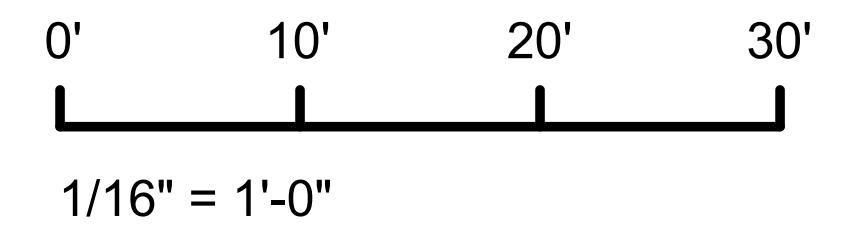

2022-11-17

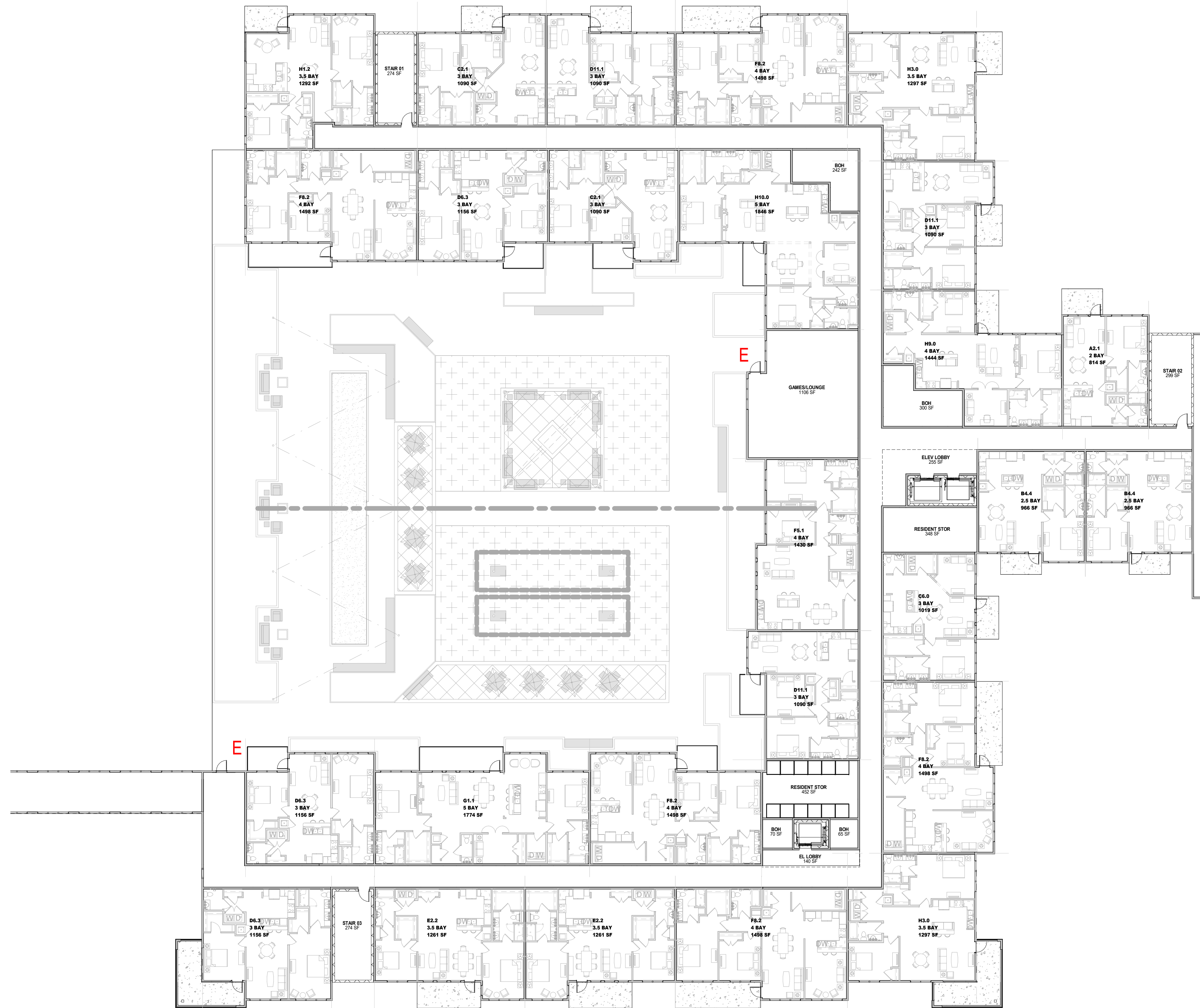

RB1.2

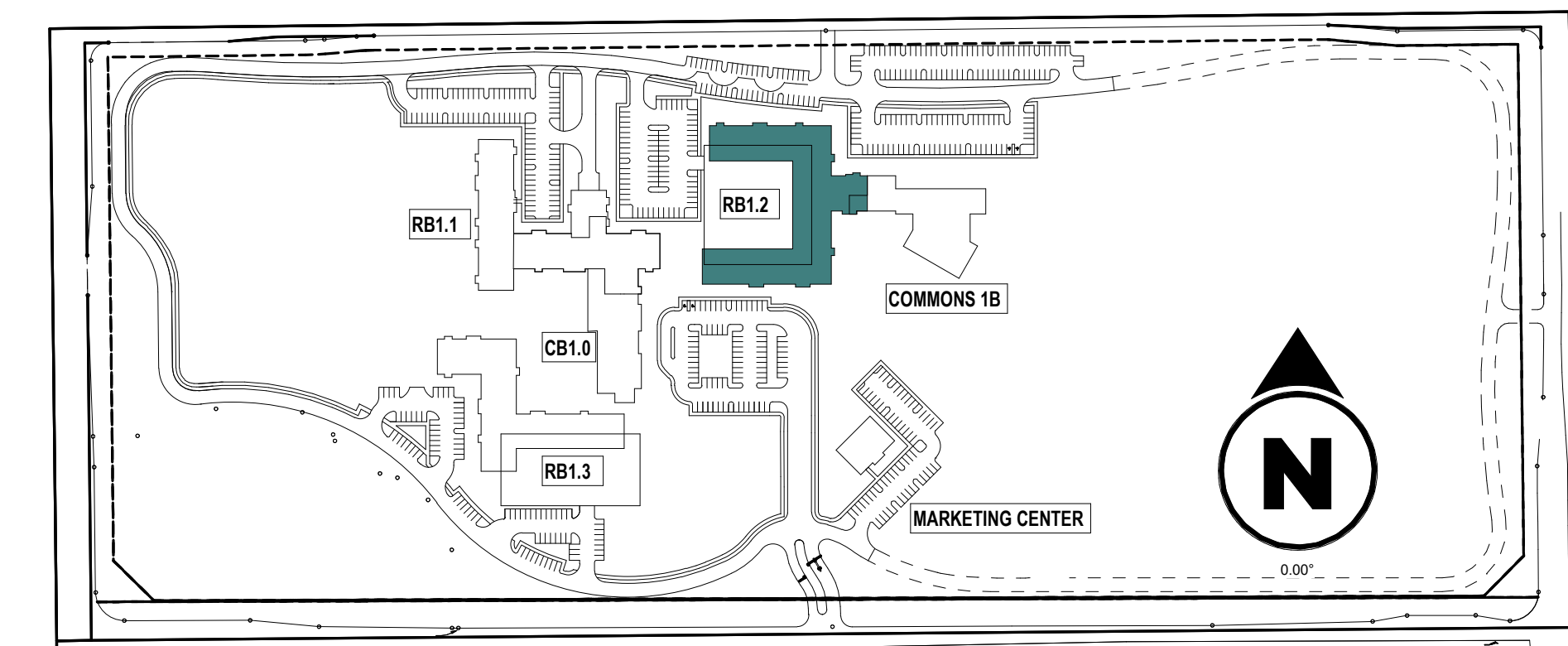

Erickson Senior Living Roseville
MPP Stage 2 Floor Plan - RB1.2 Second Level

Sierra Vista, West Roseville, CA

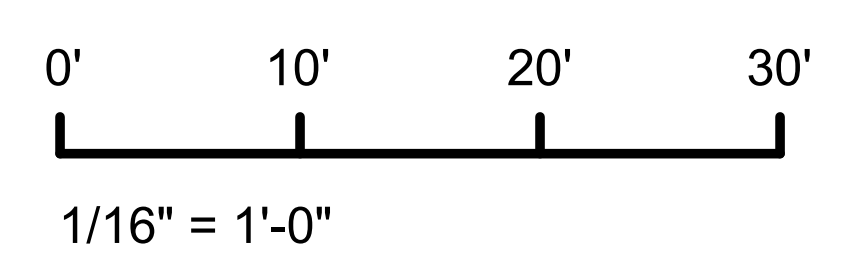

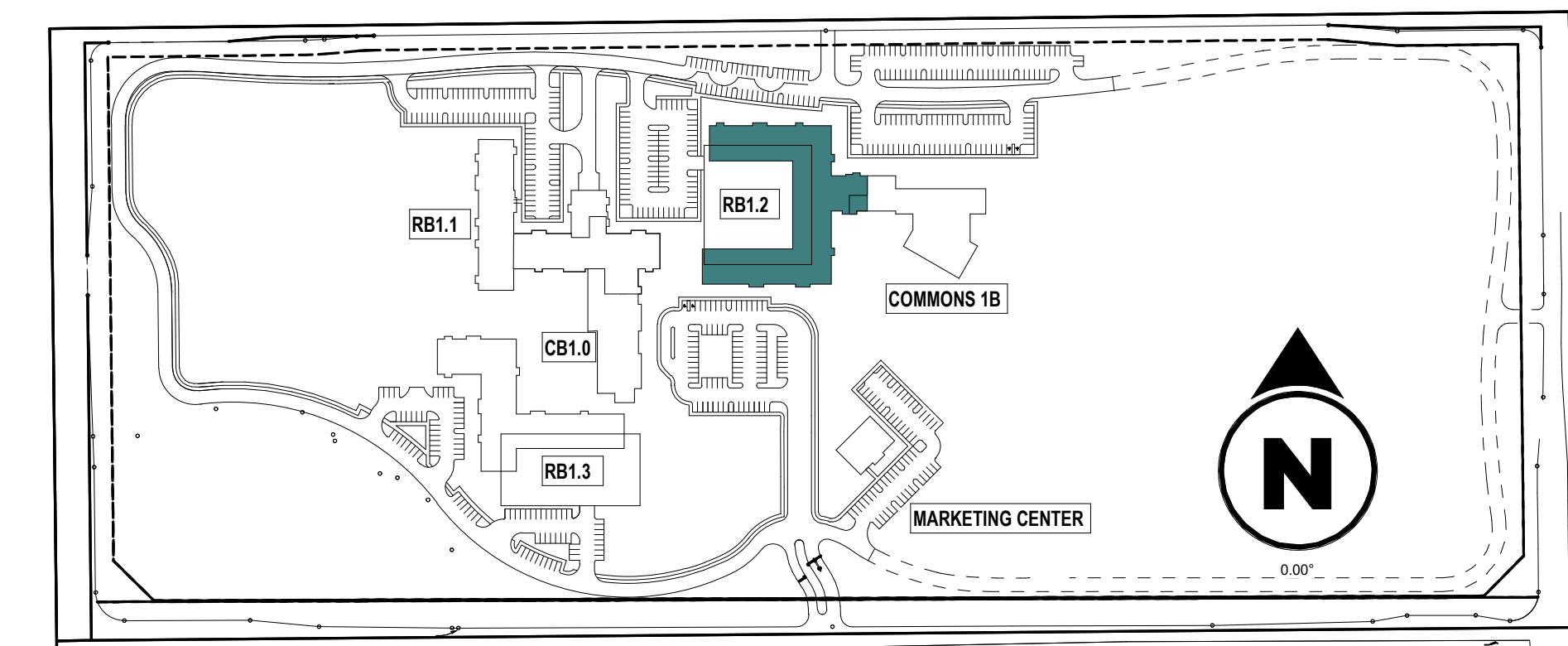

Erickson Senior Living Roseville
 MPP Stage 2 Floor Plan - RB1.2 Third-Fifth Level
 Sierra Vista, West Roseville, CA

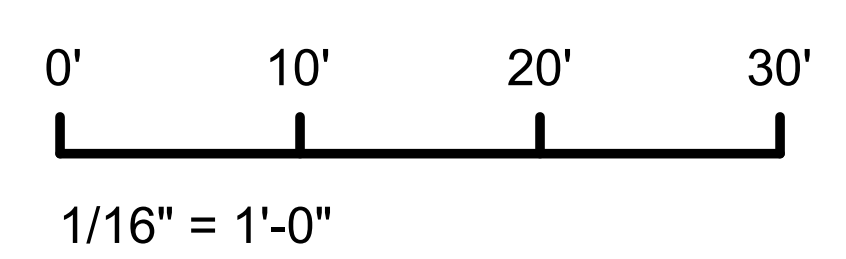

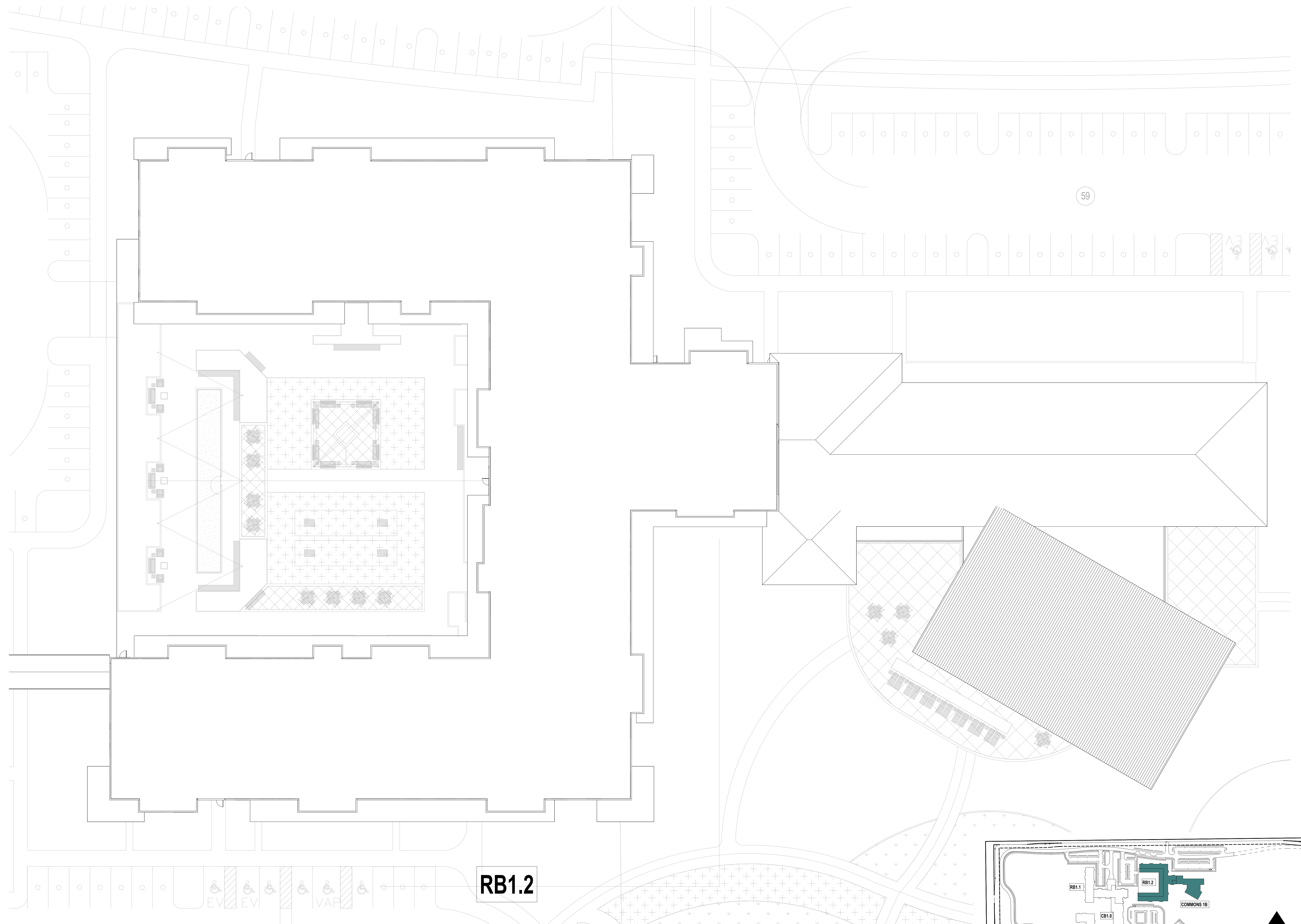

RB1.2

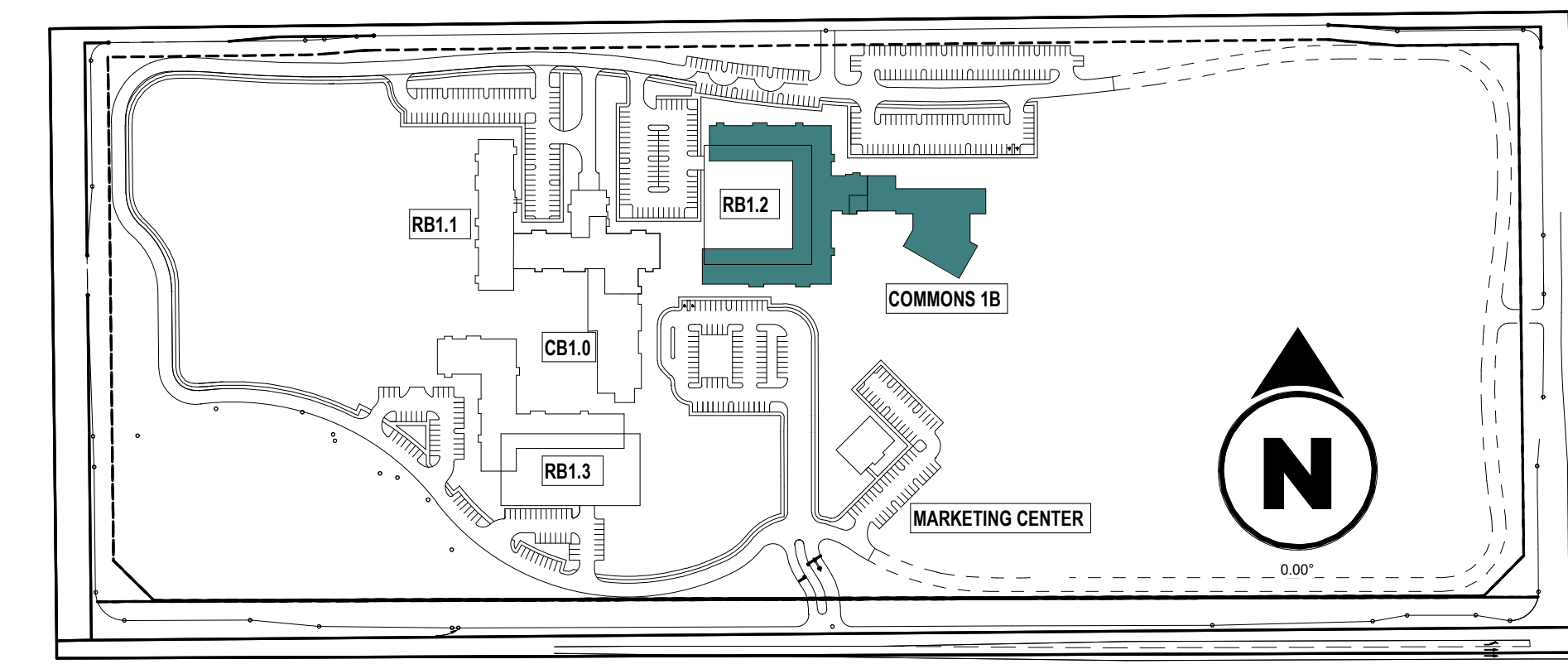

0' 10' 20' 30'
1/16" = 1'-0"



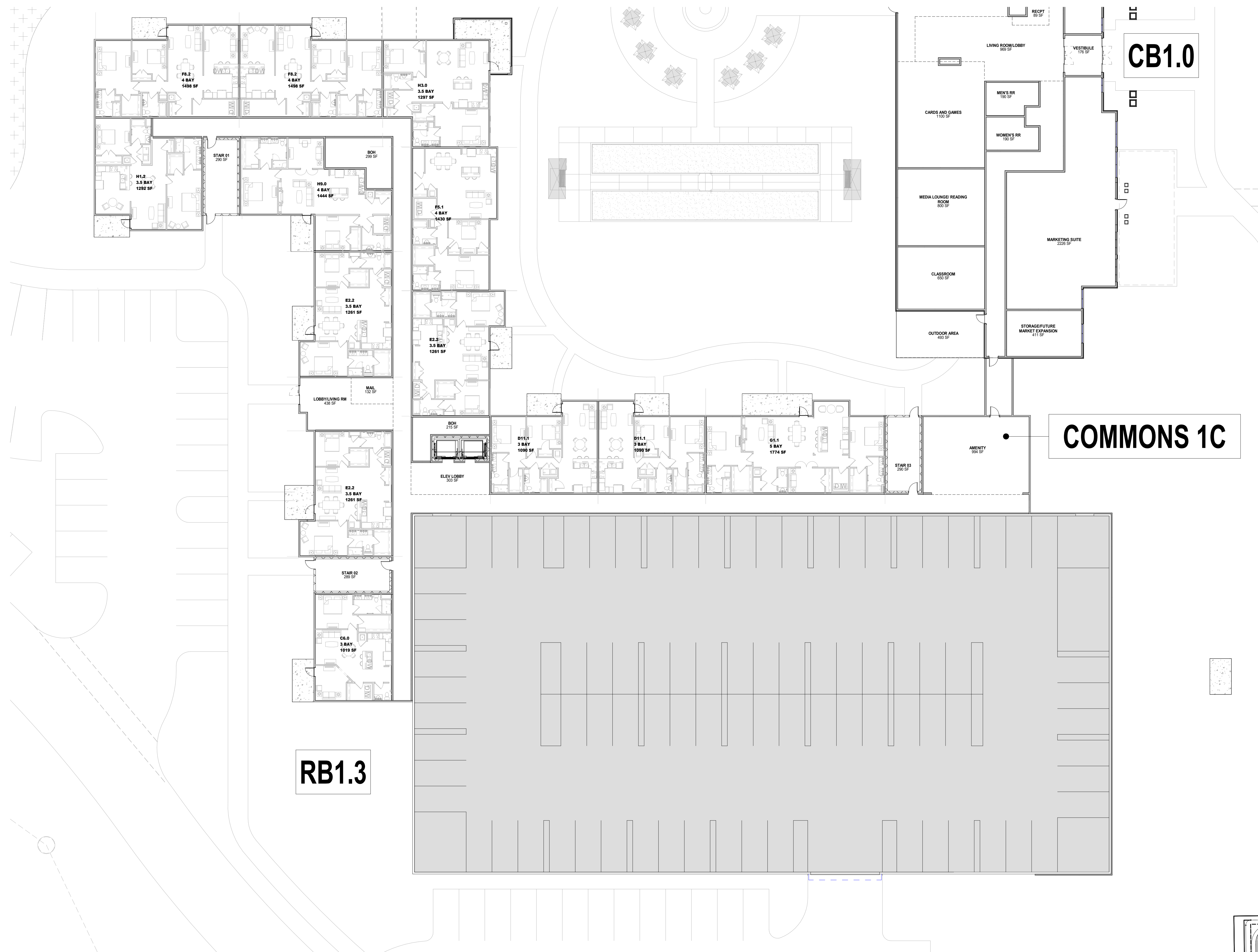

RB1.3

CB1.0

COMMONS 1C

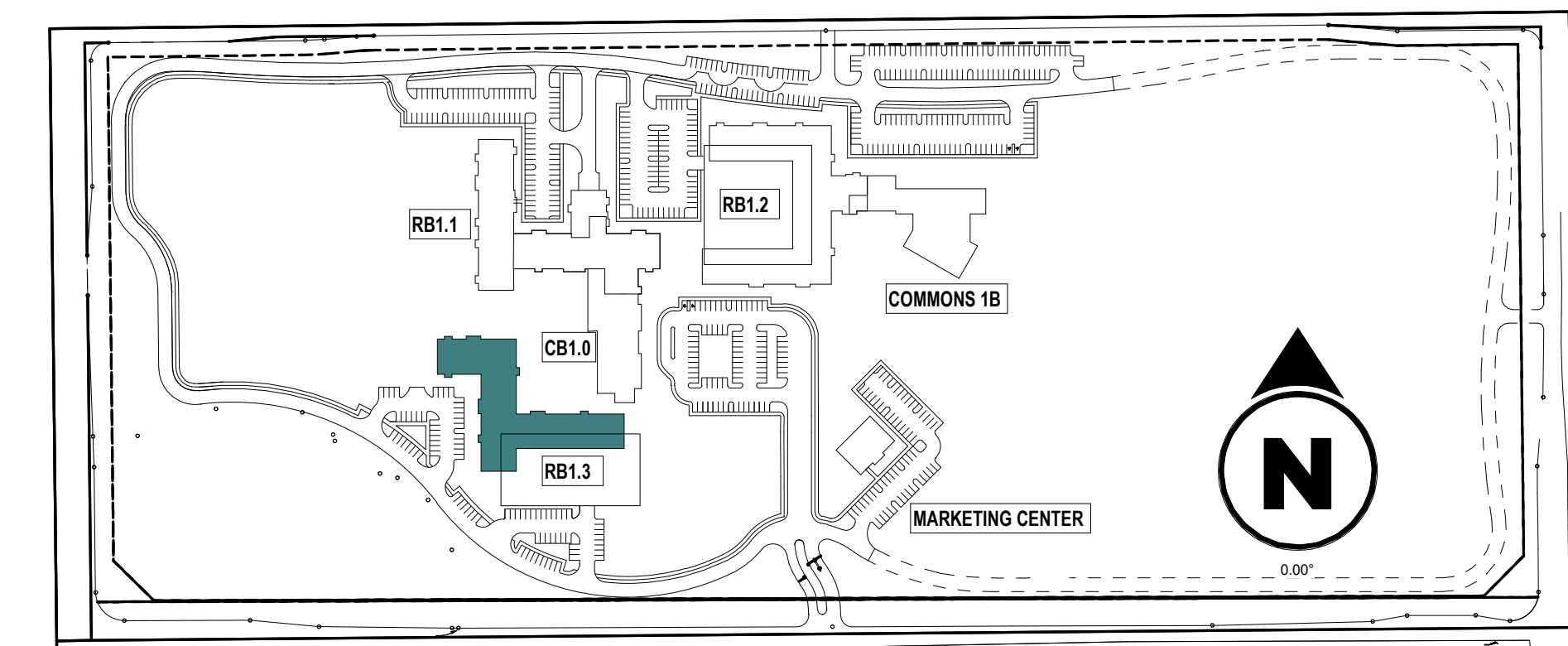

Erickson Senior Living Roseville
 MPP Stage 2 Floor Plan - RB1.3 Ground Level
 Sierra Vista, West Roseville, CA

0' 10' 20' 30'
 1/16" = 1'-0"



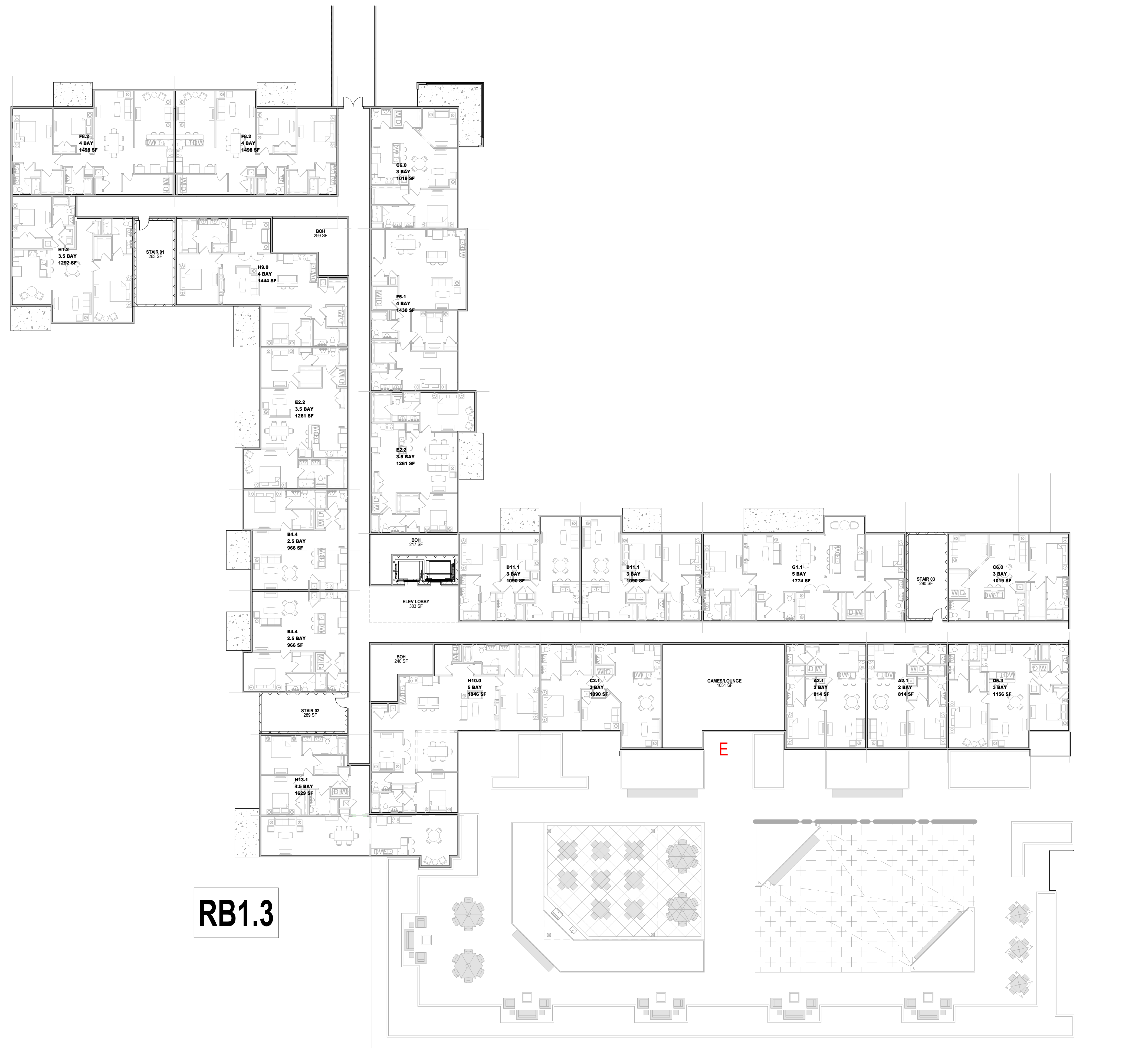

RB1.3

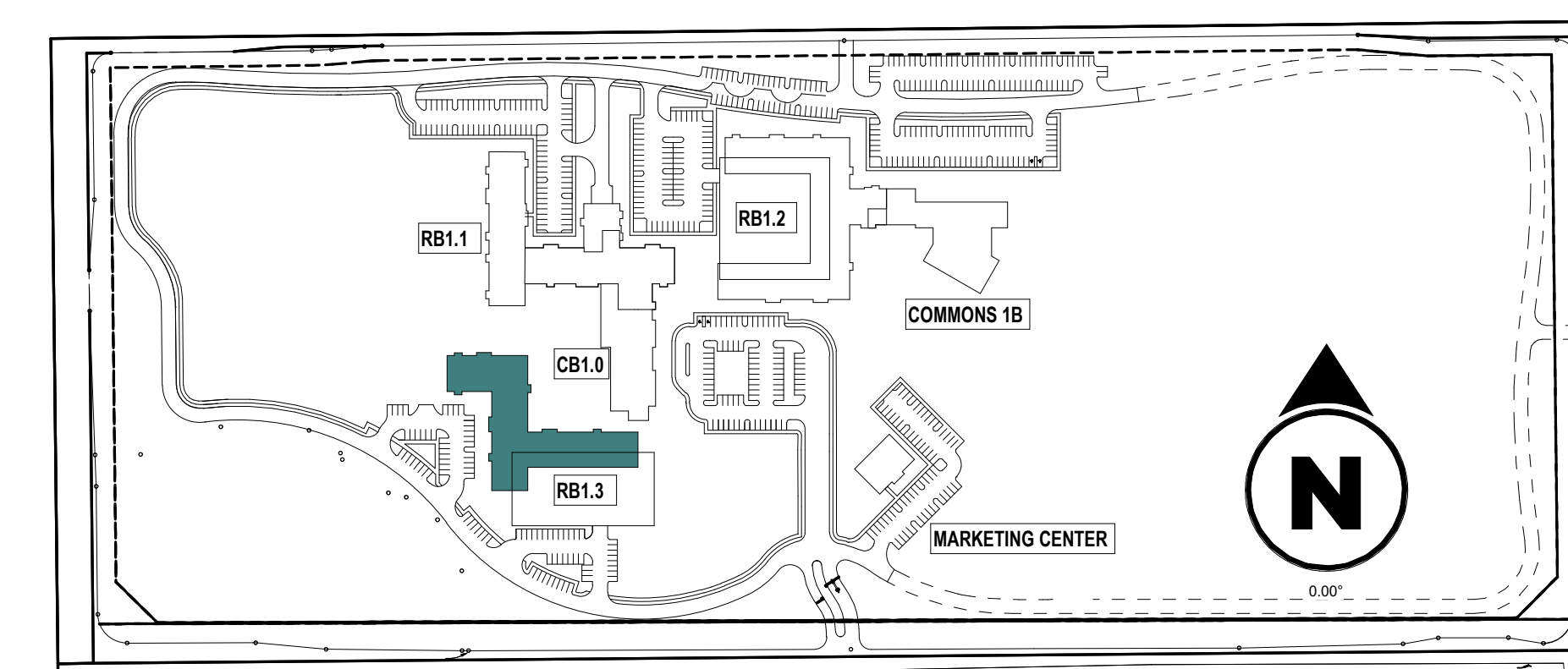

Erickson Senior Living Roseville
 MPP Stage 2 Floor Plan - RB1.3 Second Level
 Sierra Vista, West Roseville, CA

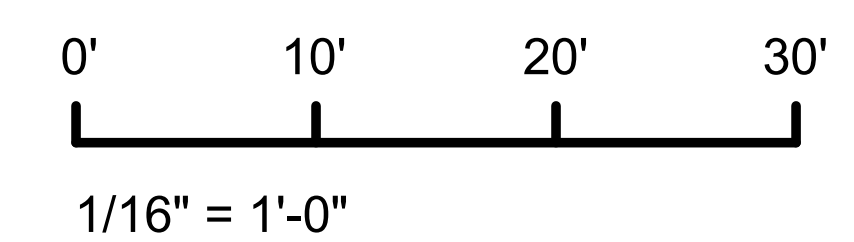

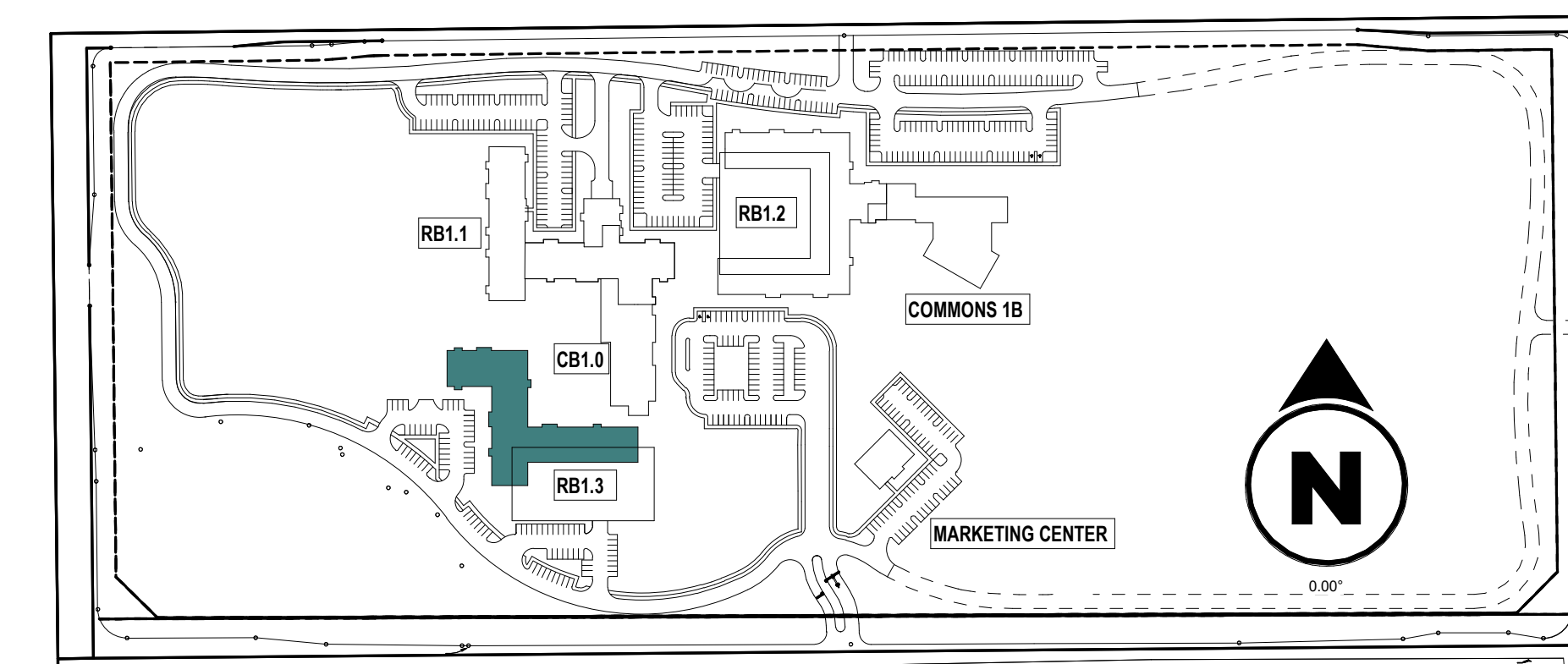

Erickson Senior Living Roseville
 MPP Stage 2 Floor Plan - RB1.3 Third-Sixth Level
 Sierra Vista, West Roseville, CA

0' 10' 20' 30'
 1/16" = 1'-0"



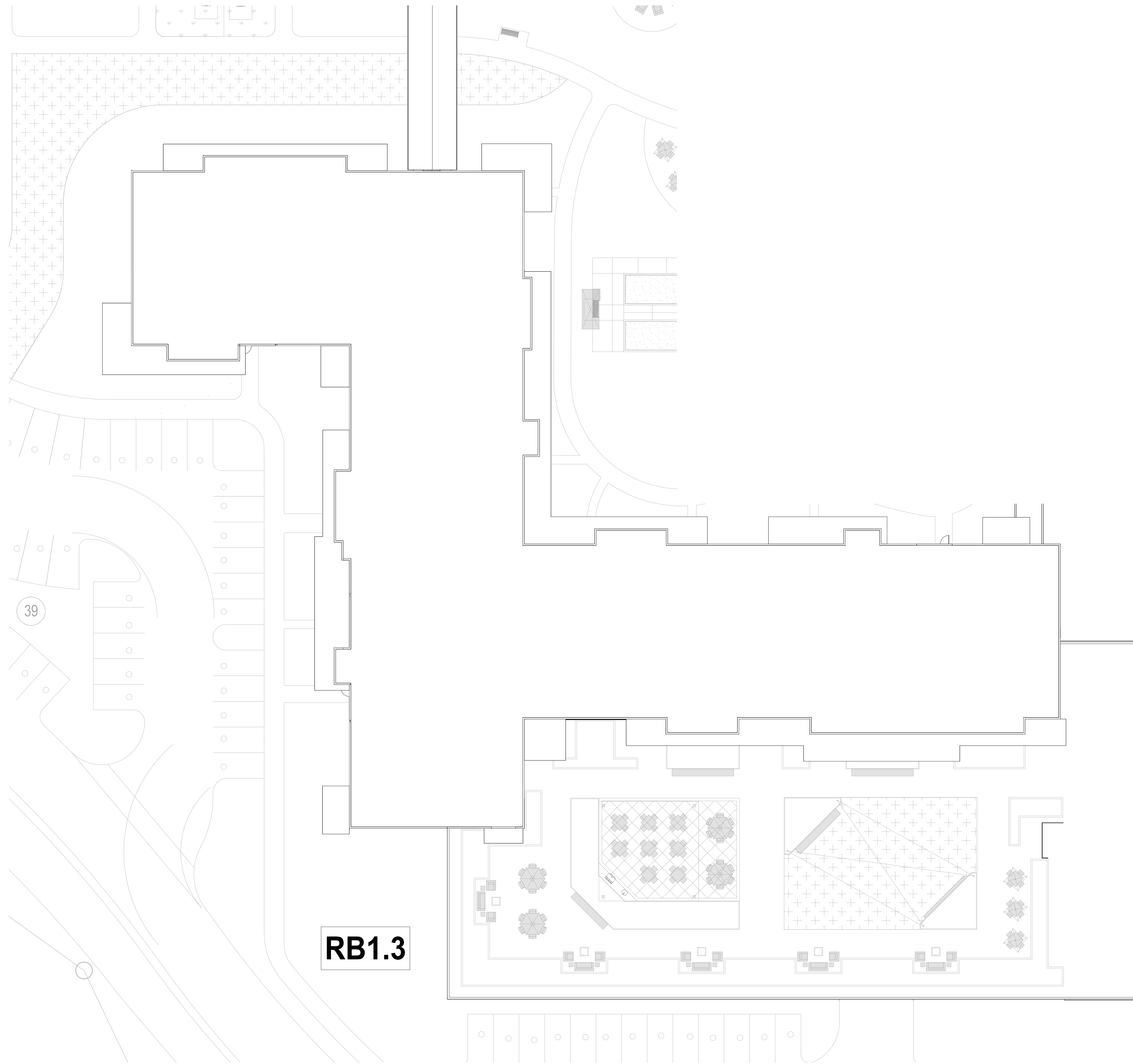

RB1.3

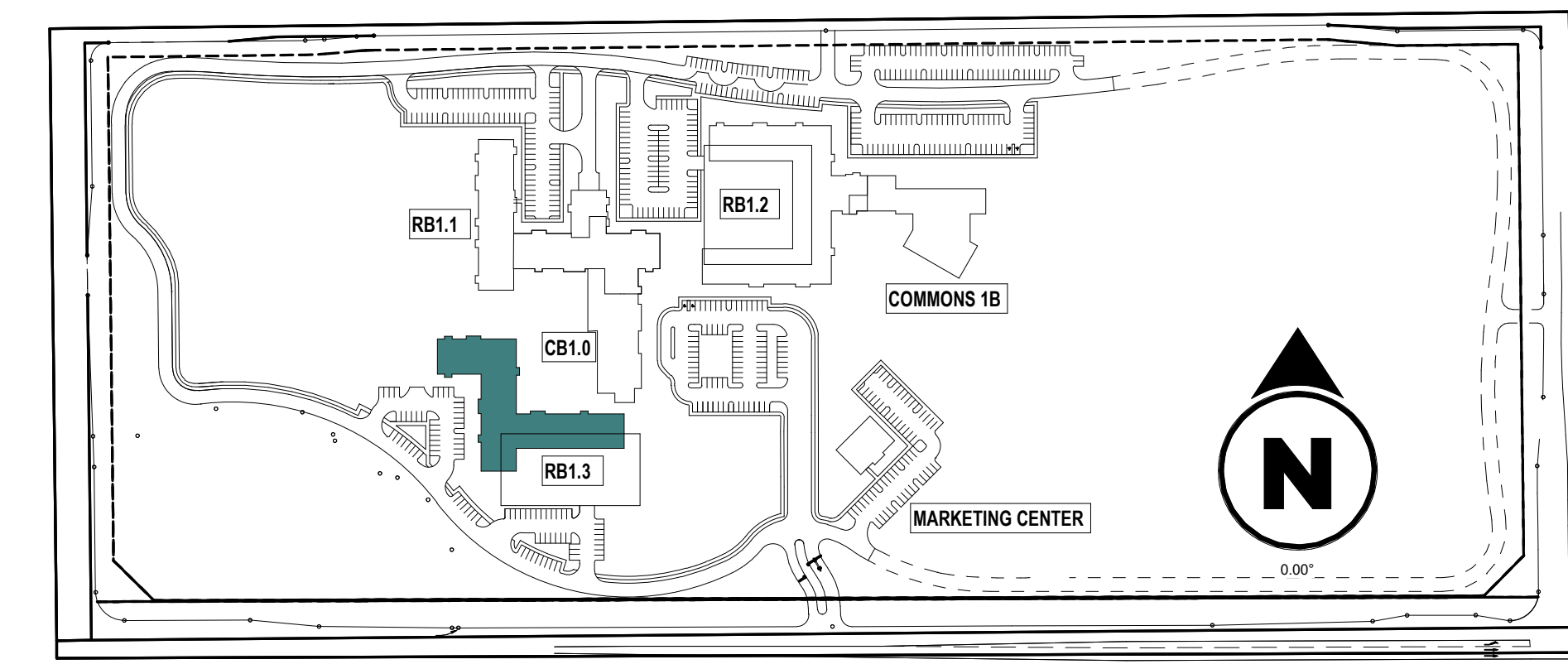

Erickson Senior Living Roseville
MPP Stage 2 Roof Plan - RB1.3
 Sierra Vista, West Roseville, CA

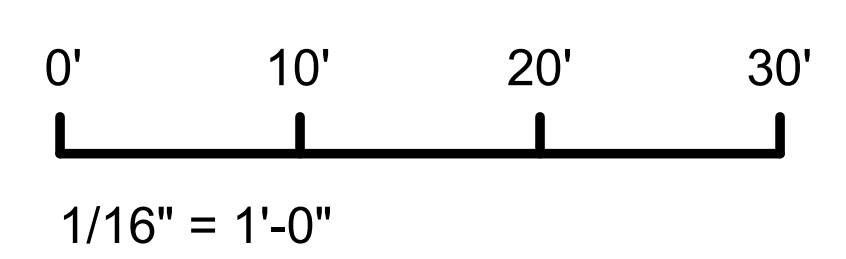

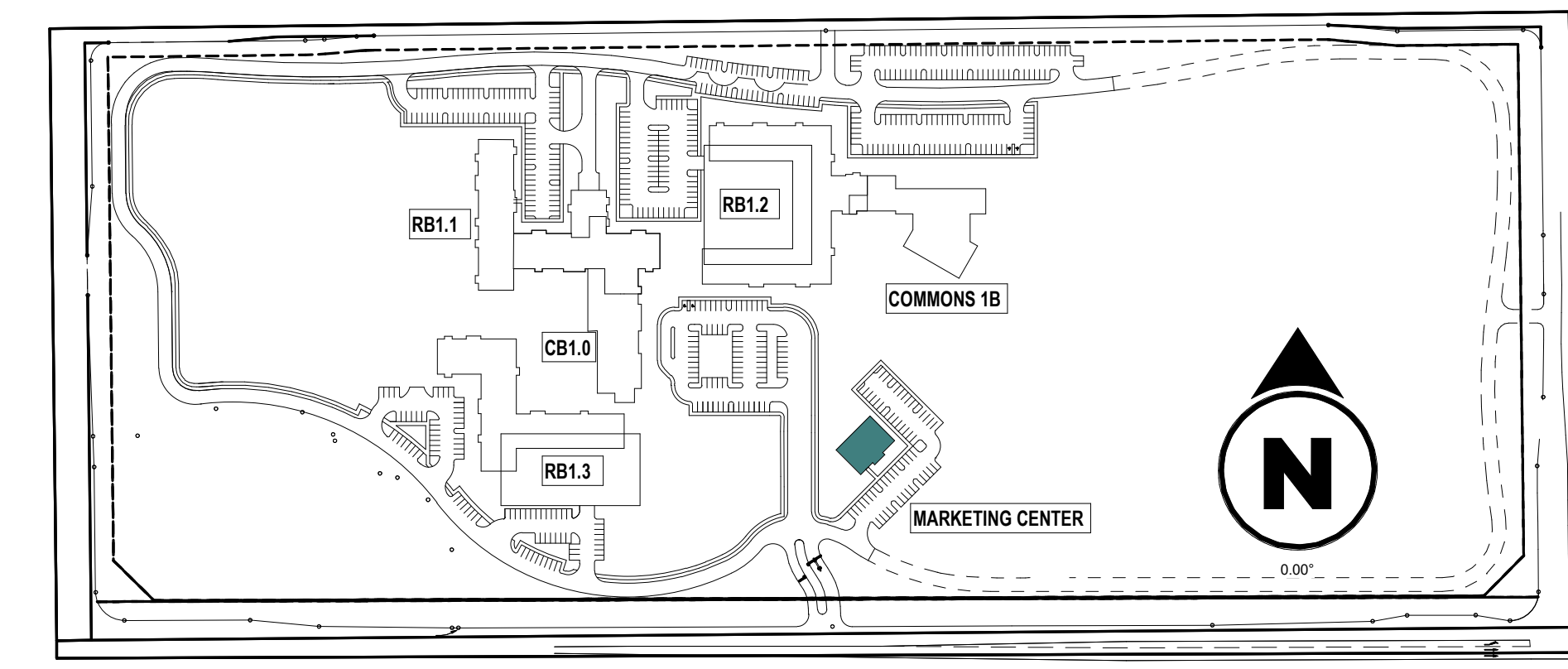
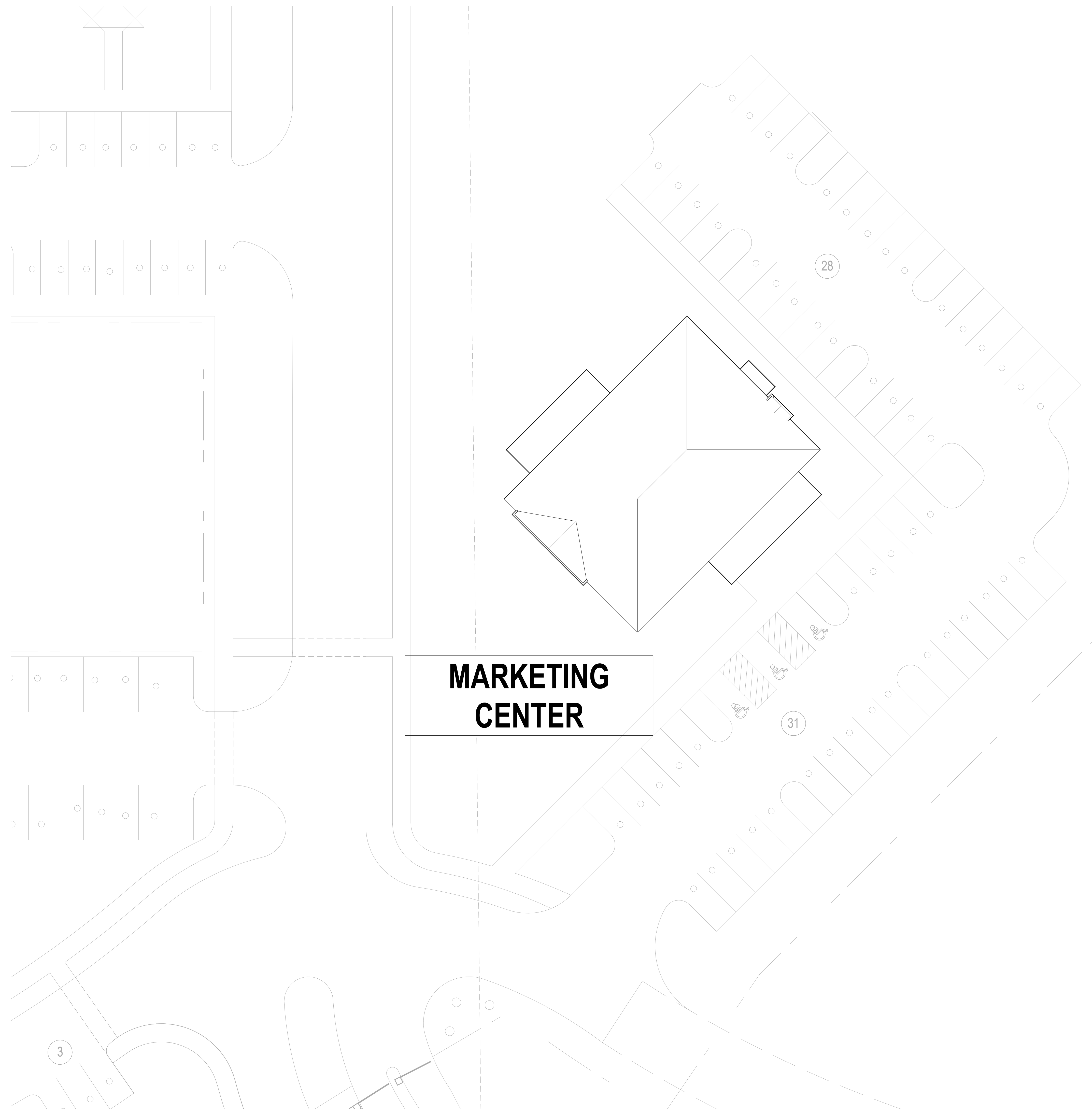

**MARKETING
CENTER**

Erickson Senior Living Roseville
MPP Stage 2 Roof Plan - Marketing Center
 Sierra Vista, West Roseville, CA

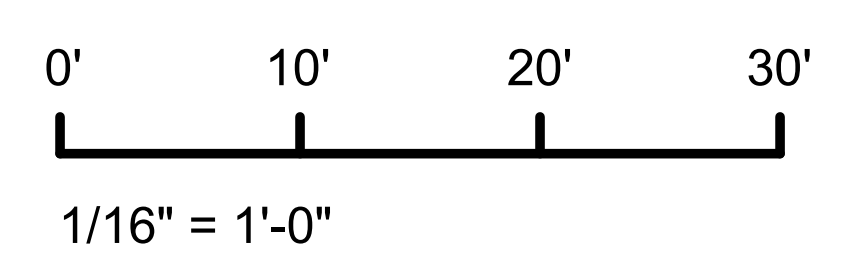

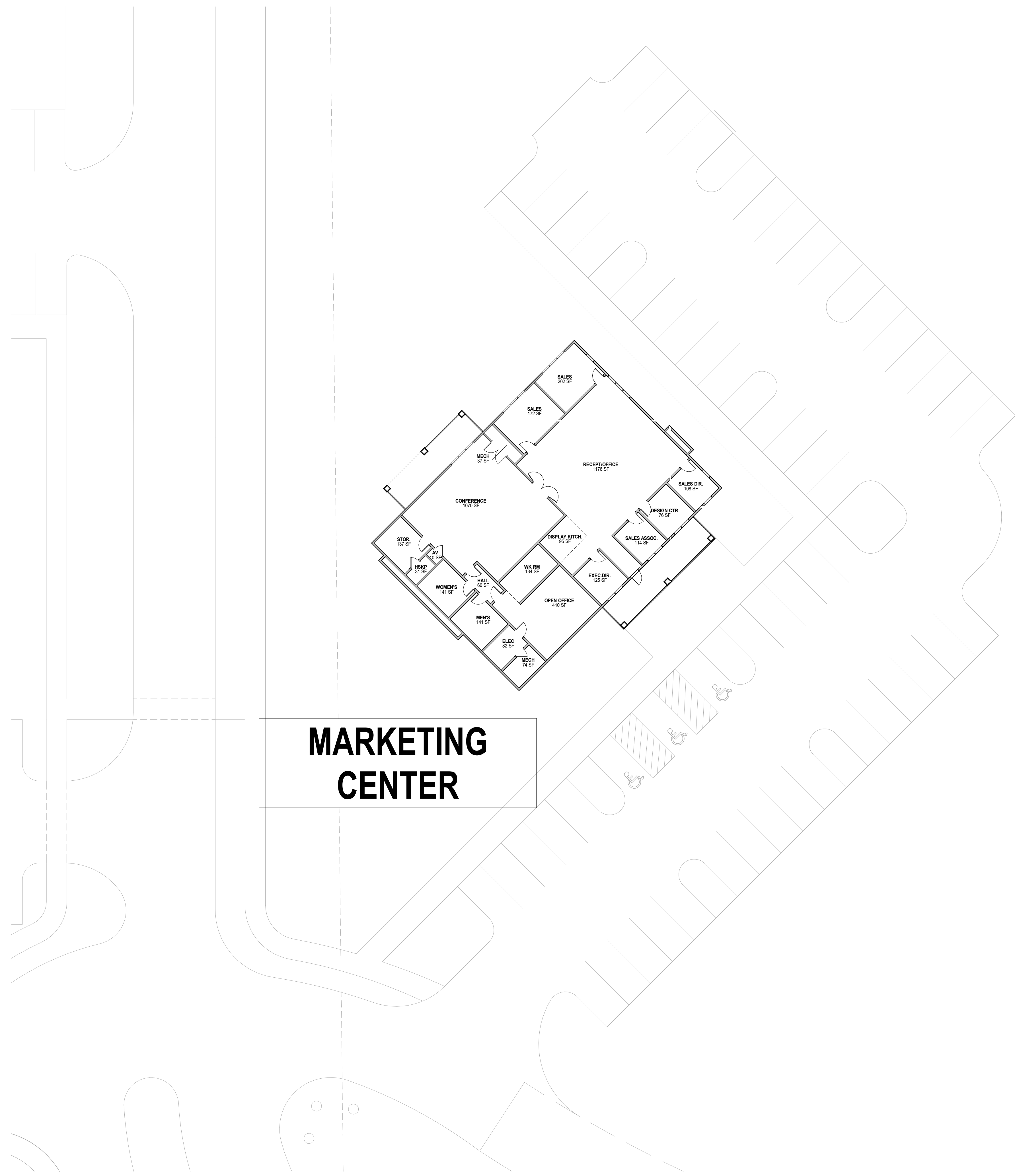

**MARKETING
CENTER**

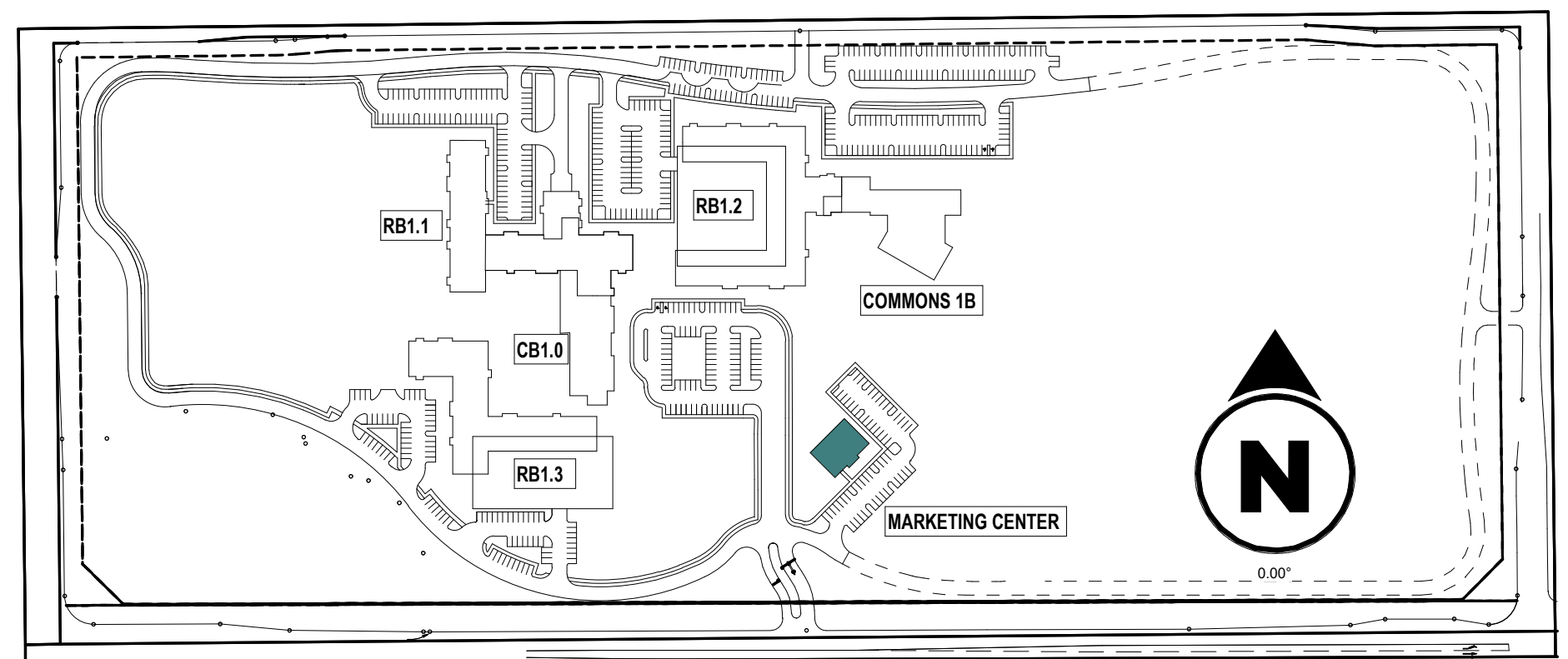

Erickson Senior Living Roseville

MPP Stage 2 Floor Plan - Marketing Center Ground Level

Sierra Vista, West Roseville, CA

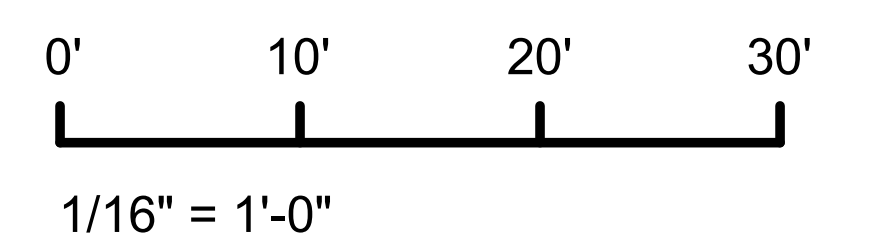

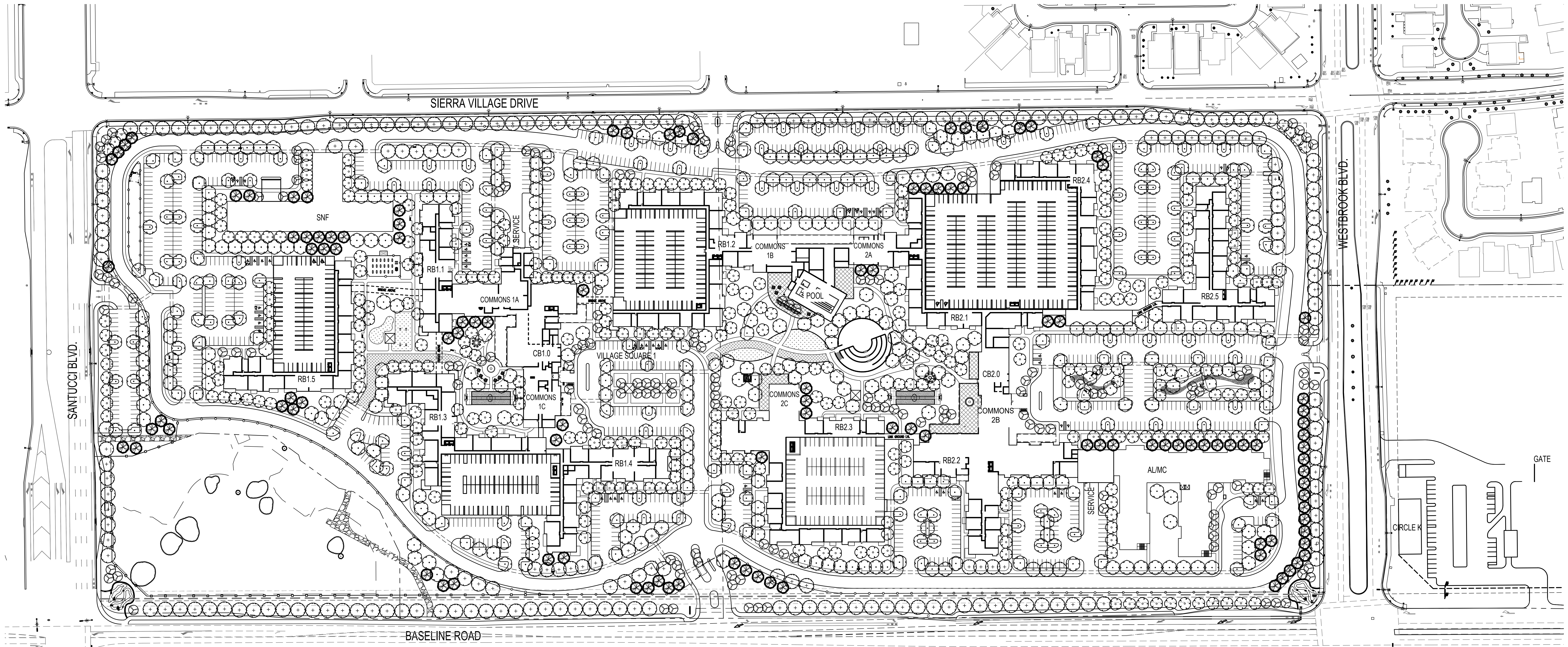

SHADE STUDY CALCULATIONS
PROJECT: ERICKSON SENIOR LIVING 11.18.2022

ENTIRE SITE (STAGE 1)			
STANDARD STALLS	1,164		314,280
COMPACT STALLS	0		0
HANDICAP STALLS	56		15,120
TOTAL PAVED PARKING AREA:			329,400
TOTAL SHADE REQUIRED:	50%		164,700
TOTAL SHADE PROVIDED:			237,926
TOTAL SHADE PERCENTAGE			72%

SYMBOL	PATTERN	QTY.	UNIT	TOTAL S.F.
30 TO 35' TREES				
ACER R., PISTACHIA C., ULMUS C., ZELKOVA S.	30-F	83	X 962	79,846
	30-TQ	31	X 722	22,382
	30-H	193	X 481	92,833
	30-Q	74	X 240	17,760
25' TO 30' TREES				
ACER B., GINGKO B., KOELREUTERIA P., ZELKOVA S.	25-F	0	X 491	0
	25-TQ	0	X 369	0
	25-H	93	X 246	22,878
	25-Q	13	X 123	1,599
15' TO 20' TREES				
CERCIS O., LAGERSTROEMIA L., MAGNOLIA G., CHITALPA T.	15-F	0	X 314	0
	15-TQ	0	X 236	0
	15-H	4	X 157	628
	15-Q	0	X 79	0
TOTAL				237,926

PRELIMINARY LANDSCAPE NOTES

- STREETSCAPE DESIGN INTENT** - STREETSCAPE WILL BE CONSISTENT WITH OTHER PROJECTS WITHIN THE SIERRA VISTA SPECIFIC PLAN AREA. WESTBROOK BLVD., SANTUCCI BLVD., & SIERRA VILLAGE DRIVE WILL UTILIZE A COMBINATION OF STREET TREES AND EVERGREEN SUBORDINATE TREES. BASELINE ROAD WILL HAVE TREES WHERE APPROPRIATE WHILE MAINTAINING CLEARANCE OF THE PG&E EASEMENT. USE OF EVERGREEN SHRUBS AND COLOR MASSES PLANTING WILL BE INCORPORATED ALONG THE STREETSCAPE. SHRUB MASSES WILL UTILIZE DROUGHT TOLERANT SPECIES WHERE APPROPRIATE.
- ENTRY TREATMENT** - ENTRY WILL BE HIGHLIGHTED BY GROVE OF ACCENT TREES WITH LOW BACKGROUND PLANTING. MONUMENT SIGNAGE WILL MAIN ENTRY AT BASELINE ROAD. UNDER STORY WILL BE LOW AND CONFORMING TO AN UNDULATED GROUND CONTOUR, WHILE MAINTAINING SIGHT LINES. USE OF COLORFUL PLANT MATERIALS WILL FURTHER ENHANCE AND DEFINE THE ENTRIES, ALONG WITH DROUGHT TOLERANT SPECIES WHERE APPROPRIATE.
- BUILDING ZONE** - FOCUS IS ON CONNECTIVITY FOR PEDESTRIANS. A VARIETY OF COLUMNAR AND SMALL SCALE TREES WITH LOW CONTRASTING SHRUB FORMS WILL BE USED TO ADD INTEREST, COLOR, AND TEXTURE. SEVERAL OUTDOOR PLAZA SPACES WITH TREE WELLS WILL BE INCORPORATED BETWEEN BUILDINGS.
- PARKING LOT INTENT** - DESIGNATED TREES WILL PROVIDE A CANOPY OF SHADE UNDER STORY PLANTINGS WITHIN THE PARKING LOT WILL CONSIST OF LOW SHRUBBERY AND/OR GROUND COVERS. PEDESTRIAN ACCESS IS PROVIDED FROM PARKING LOT TO ADJACENT EXISTING BIKE TRAIL ALONG THE SOUTH PROPERTY LINE.
- MONUMENT SIGNAGE** CONSISTENT WITH THE SIERRA VISTA SPECIFIC PLAN WILL BE INSTALLED AT THE CORNERS OF BASELINE ROAD AND SANTUCCI BLVD. AND BASELINE ROAD AND WESTBROOK BLVD.
- PROJECT HAS A PLANNED WALKING PATH** AROUND THE PERIMETER WITH INTERIOR WALKING LOOPS. MILEAGE SIGNAGE AND SHADED BENCHES WILL BE INCLUDED ALONG THE PATH.

CONCEPT PLANT SCHEDULE

- SHADE TREES**
 - ACER RUBRUM 'OCTOBER GLORY' / OCTOBER GLORY RED MAPLE (40'X35')
 - CELTIS OCCIDENTALIS / CHINESE HACKBERRY (40'X40')
 - PISTACHIA CHINENSIS / CHINESE PISTACHE (40'X40')
 - ZELKOVA SERRATA 'VILLAGE GREEN' / VILLAGE GREEN SAWLEAF ZELKOVA (50'X35')
- SCREEN TREES**
 - CEDRUS DEODARA / DEODAR CEDAR (60'X40")
 - PODOCARPUS GRACILIOR / FERN PINE (40'X20")
 - QUERCUS ILEX / HOLLY OAK (60'X40")
- ACCENT TREES**
 - CERCIS OCCIDENTALIS / WESTERN REDBUD (18'X18')
 - LAGERSTROEMIA INDICA 'FAURIEI' / ARAPAHO' / RED CRAWPE MYRTLE (25'X20')
 - MAGNOLIA GRANDIFLORA 'LITTLE GEM' / LITTLE GEM DWARF MAGNOLIA (25'X15")
 - XCHITALPA TASHKENTENSIS 'PINK DAWN' / PINK DAWN CHITALPA (30'X25')
- SUBORDINATE TREES**
 - ACER BUERGERIANUM / TRIDENT MAPLE (25'X25')
 - GINGKO BILOBA 'PRINCETON SENTRY' / MAIDENHAIR TREE (40'X20')
 - KOELREUTERIA PANICULATA / GOLDEN RAIN TREE (35'X30')
 - ZELKOVA SERRATA 'MUSASHINO' / MUSASHINO SAWLEAF ZELKOVA (40'X15')
- STREET TREE**
 - LIRIODENDRON TULIPIFERA / TULIP TREE (60'X40')
 - QUERCUS RUBRA / RED OAK (60'X45')



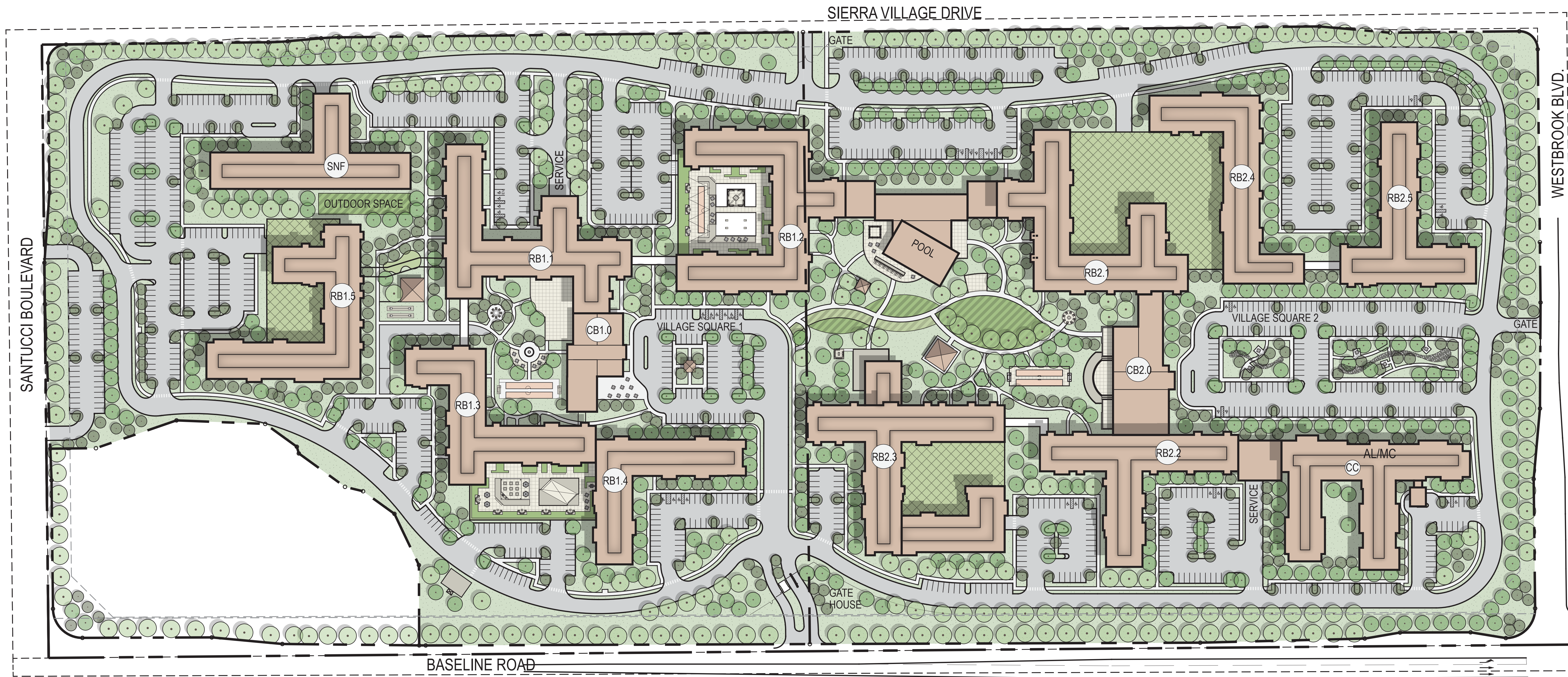

SITE PLAN

ERICKSON SENIOR LIVING ROSEVILLE

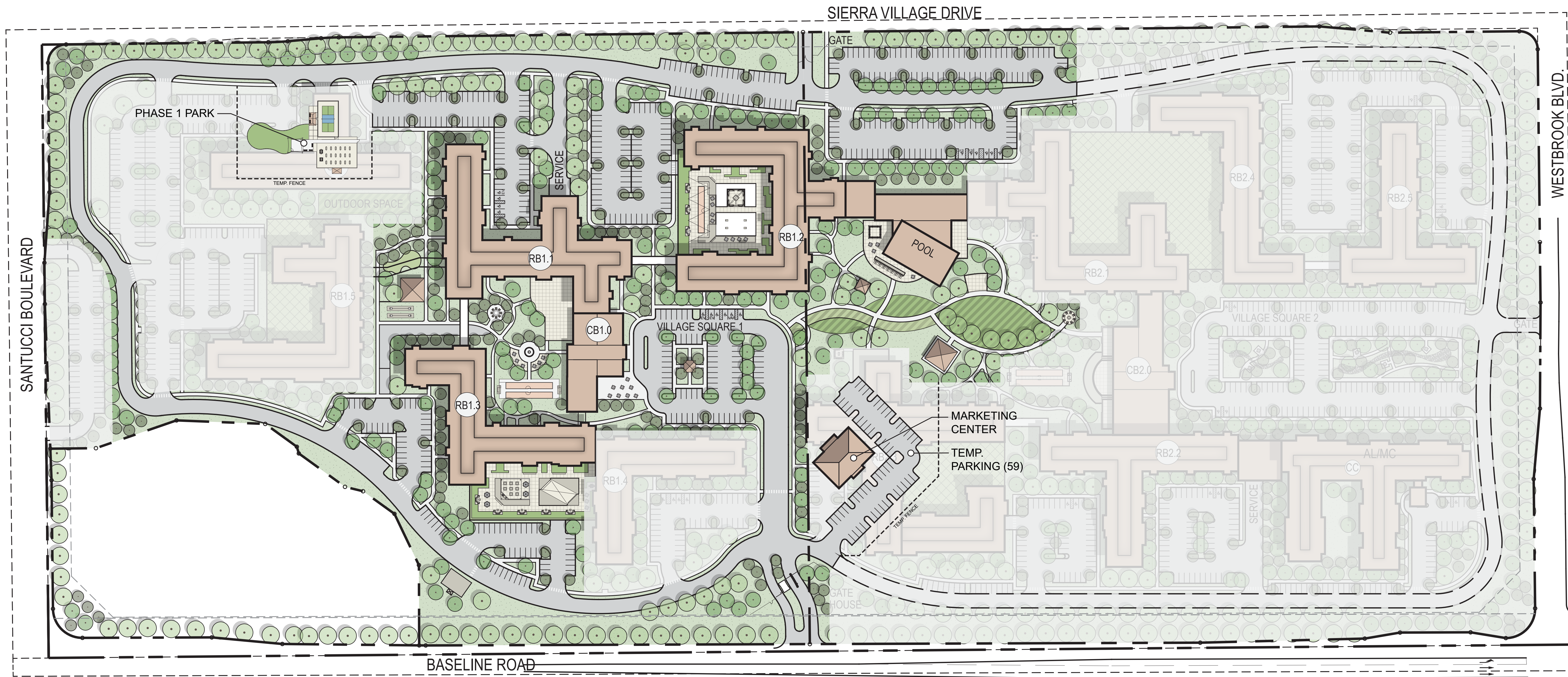

PHASING PLAN - PHASE 1

ERICKSON SENIOR LIVING ROSEVILLE

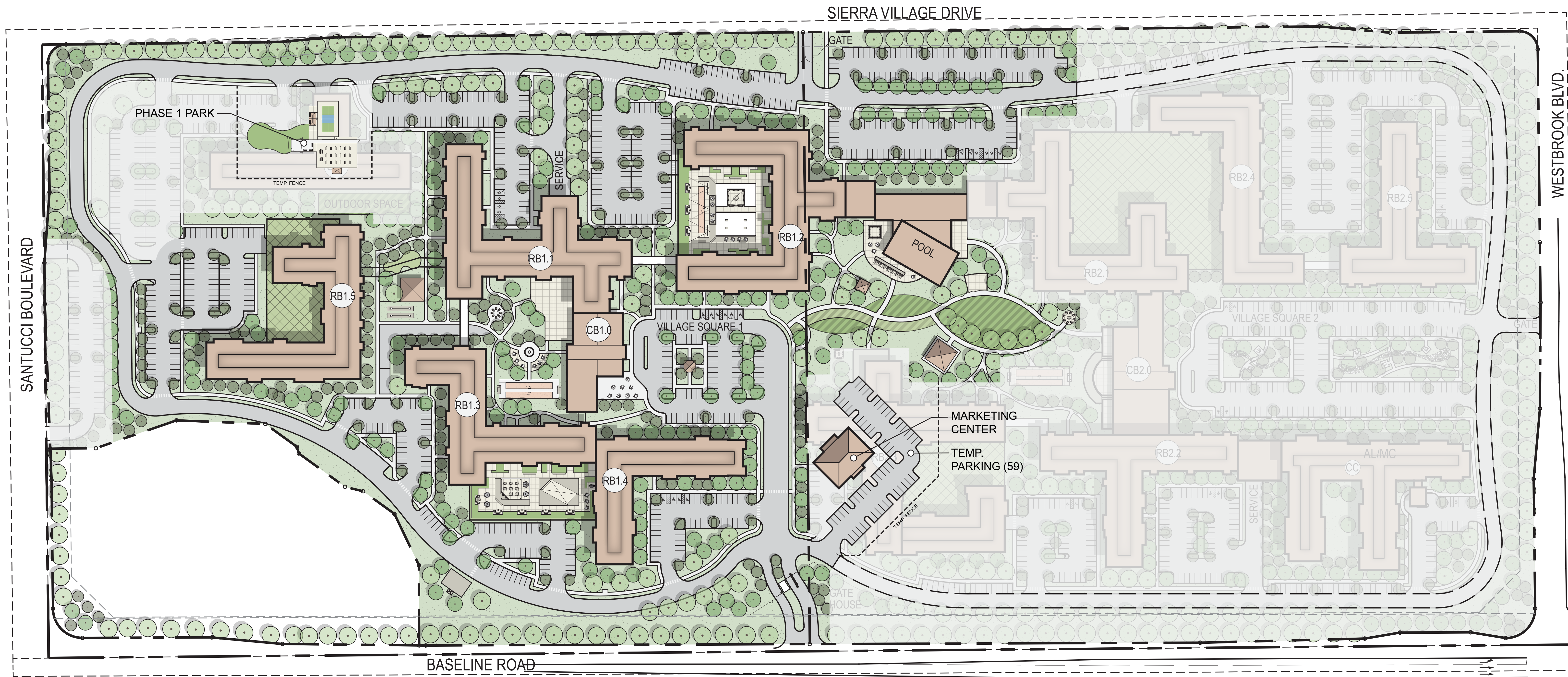

PHASING PLAN - PHASE 2

ERICKSON SENIOR LIVING ROSEVILLE

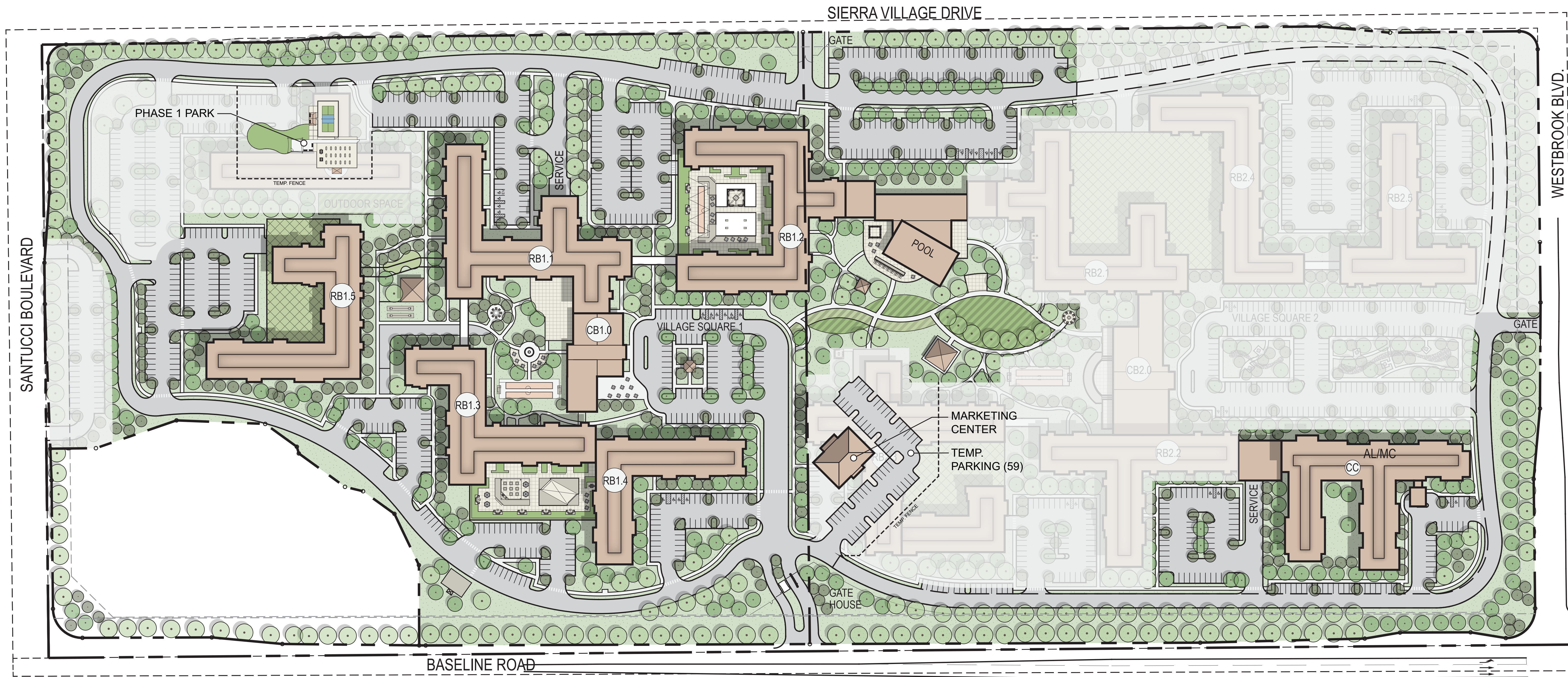

PHASING PLAN - PHASE 3

ERICKSON SENIOR LIVING ROSEVILLE

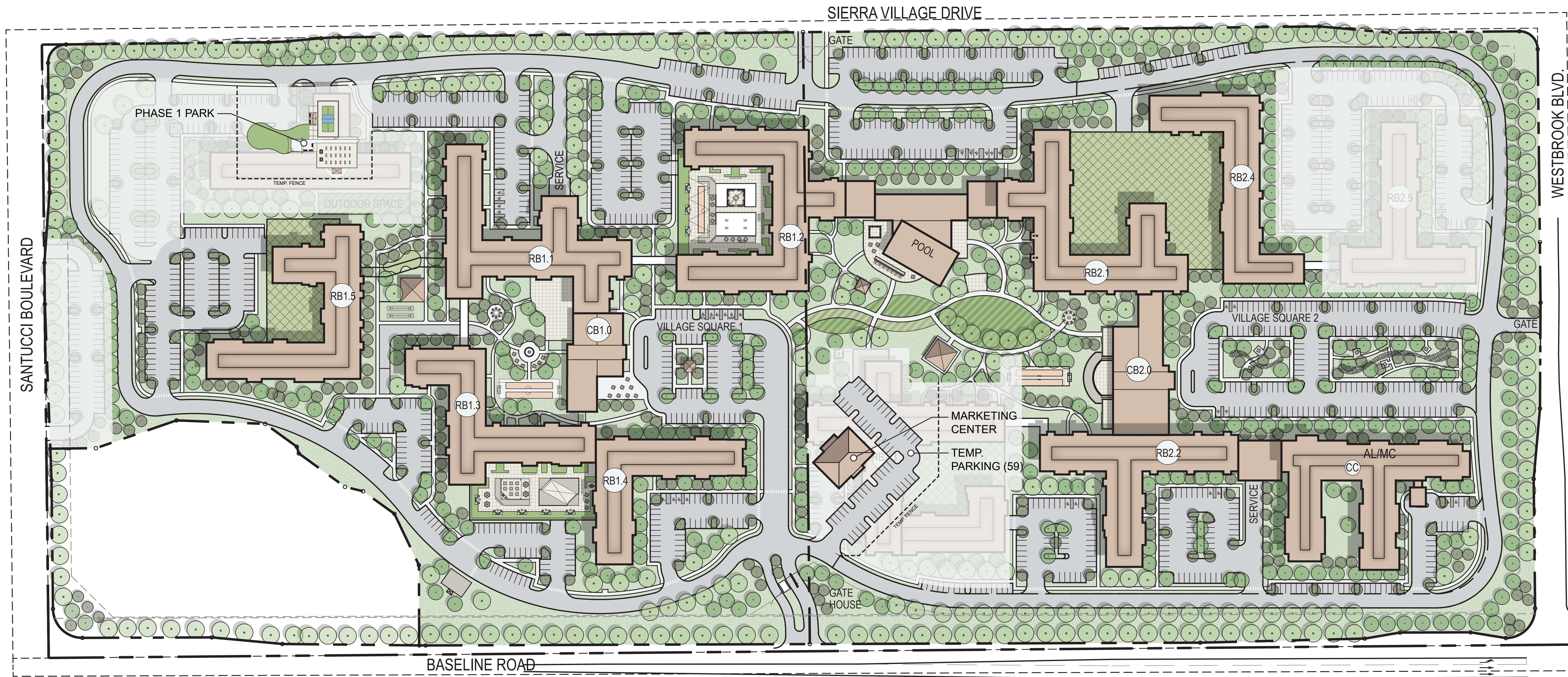

PHASING PLAN - PHASE 4

ERICKSON SENIOR LIVING ROSEVILLE

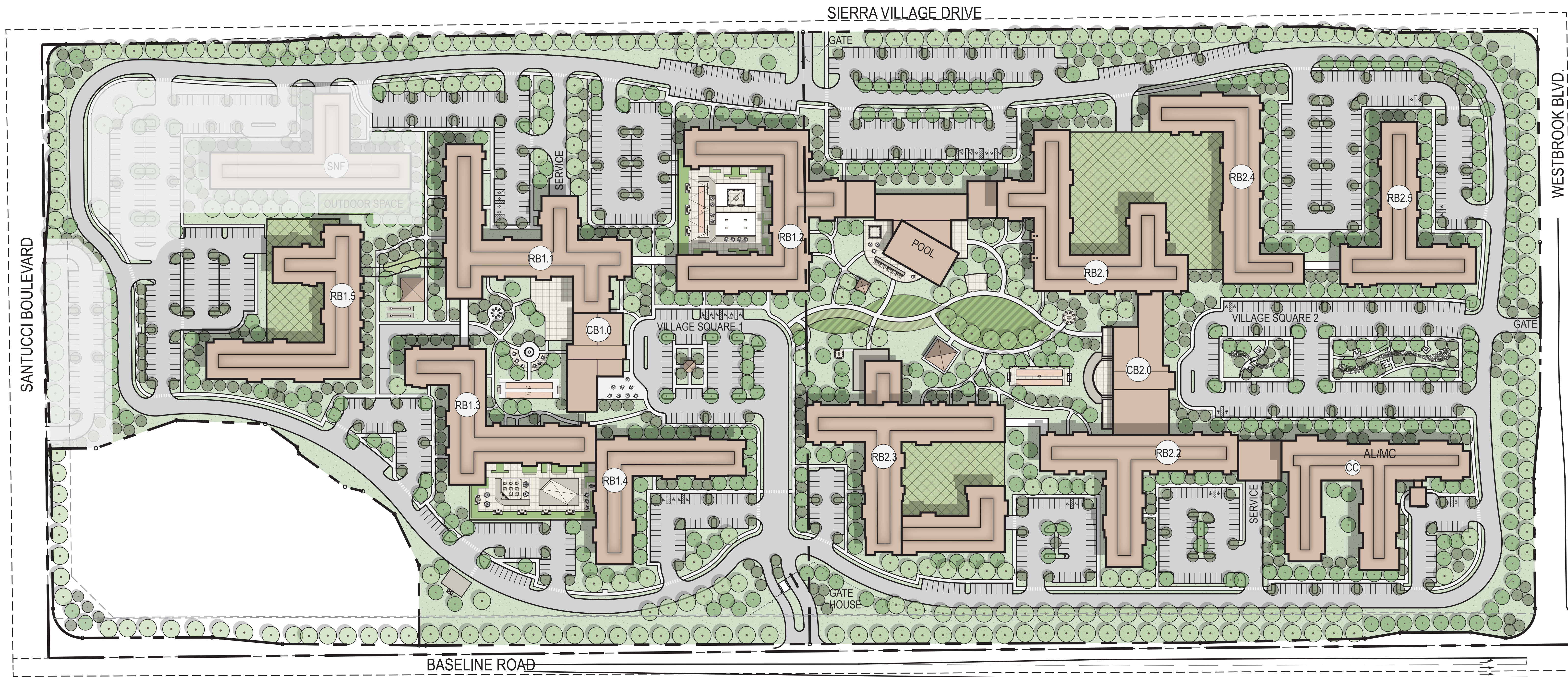

PHASING PLAN - PHASE 5

ERICKSON SENIOR LIVING ROSEVILLE

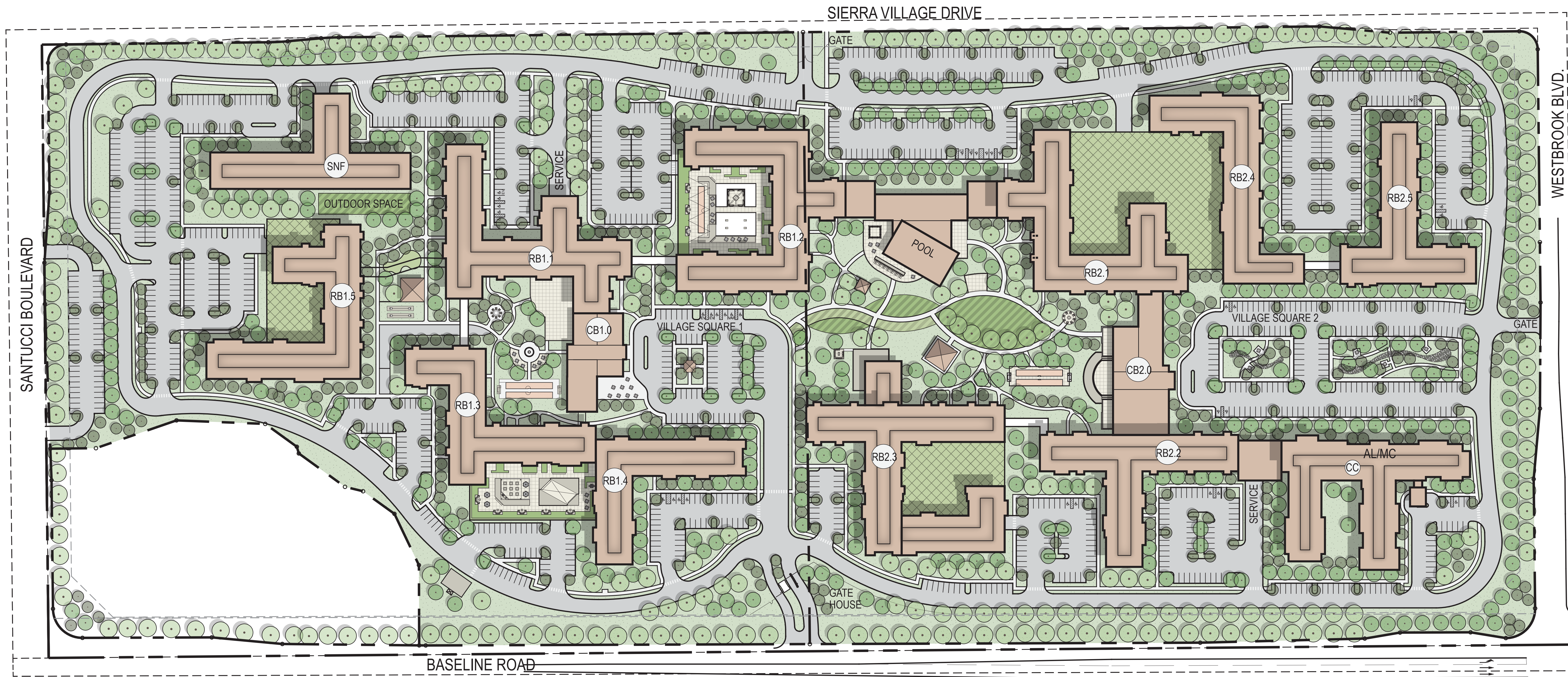

PHASING PLAN - PHASE 6

ERICKSON SENIOR LIVING ROSEVILLE

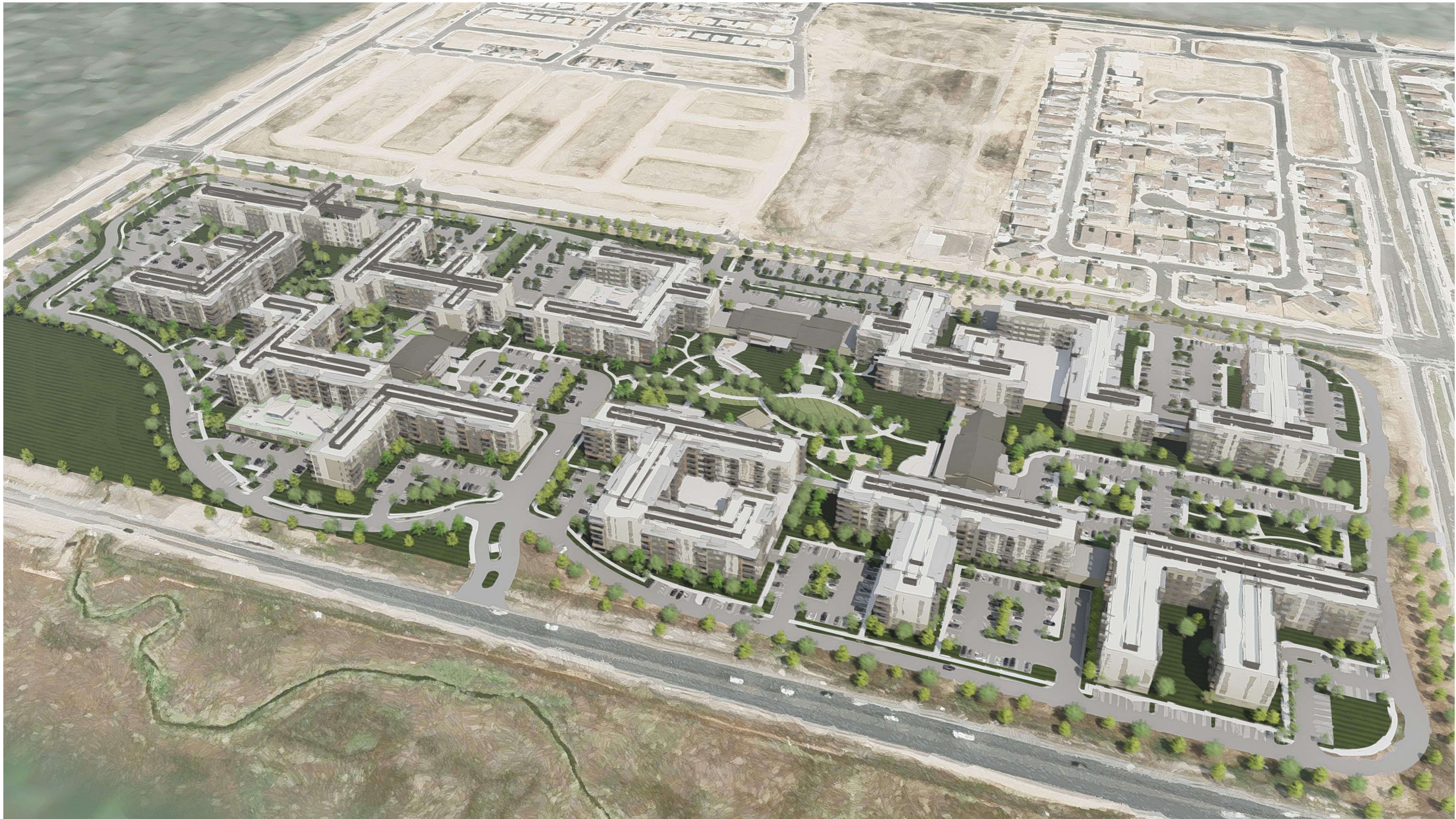

AERIAL VIEW FROM SOUTH



AERIAL VIEW FROM SOUTHWEST



AERIAL VIEW FROM SOUTHEAST



AERIAL VIEW FROM NORTH

ERICKSON SENIOR LIVING ROSEVILLE

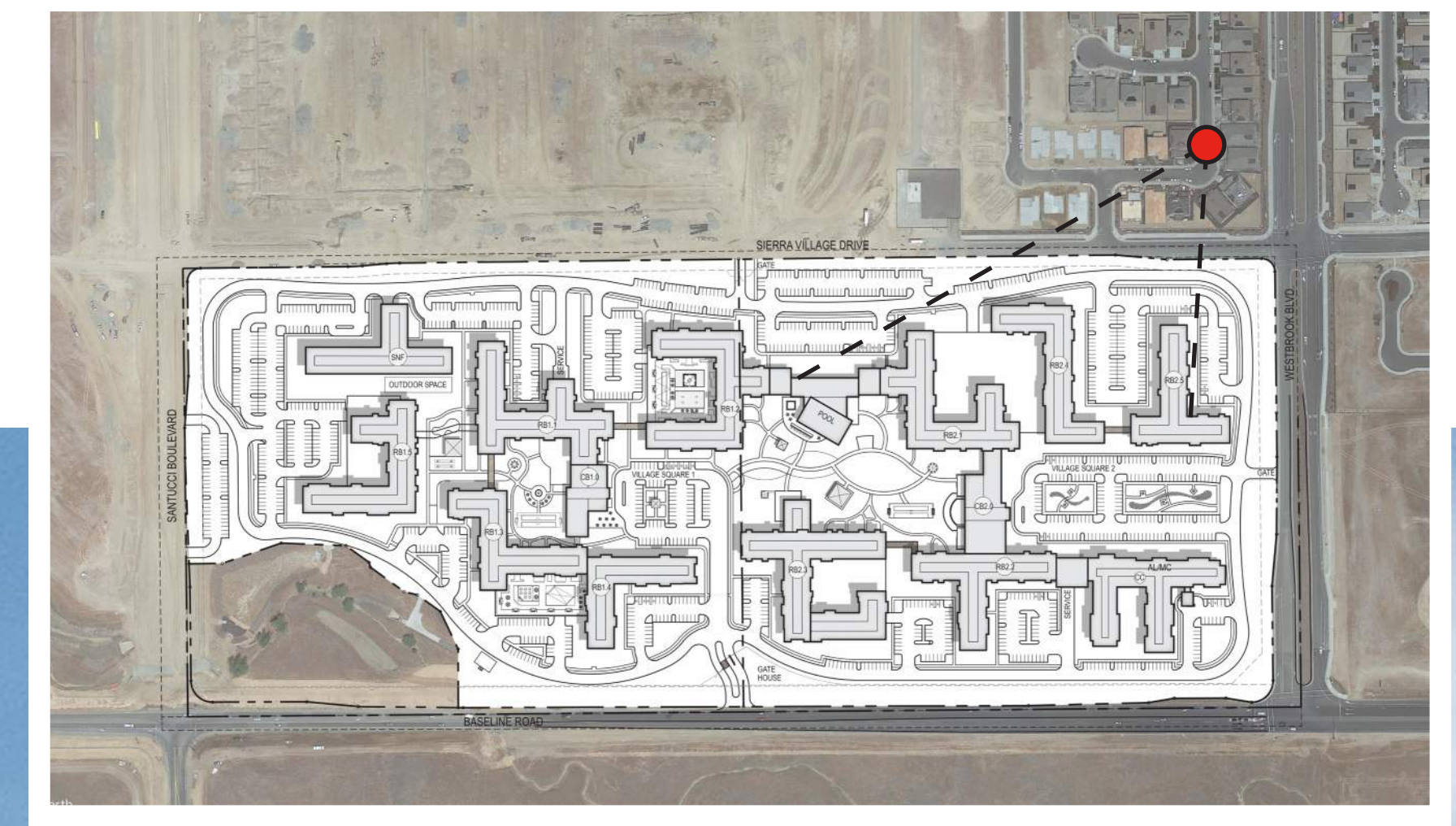

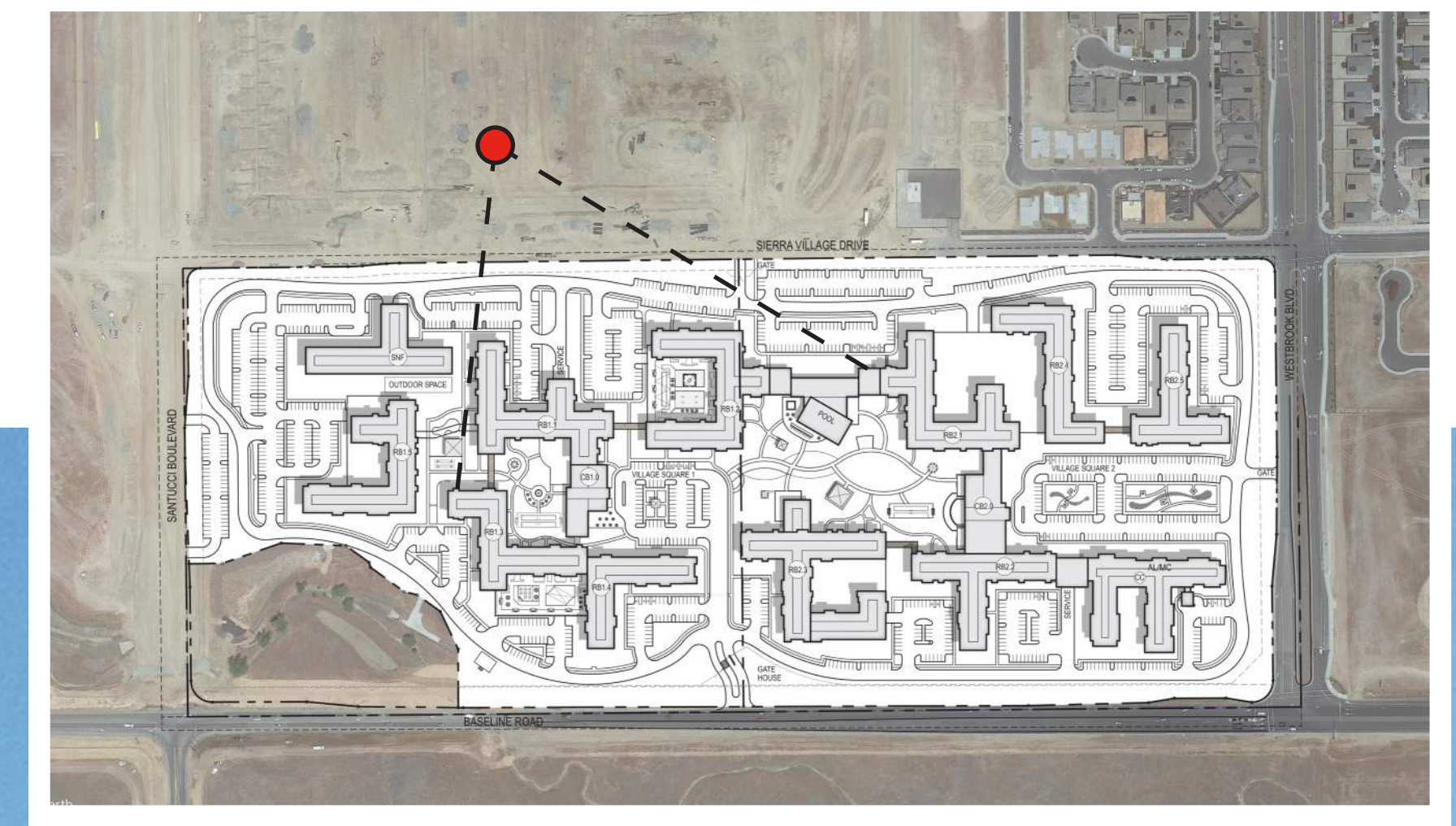

VIEW FROM HOLLOWTOP WAY NORTH OF SIERRA MORENA WAY

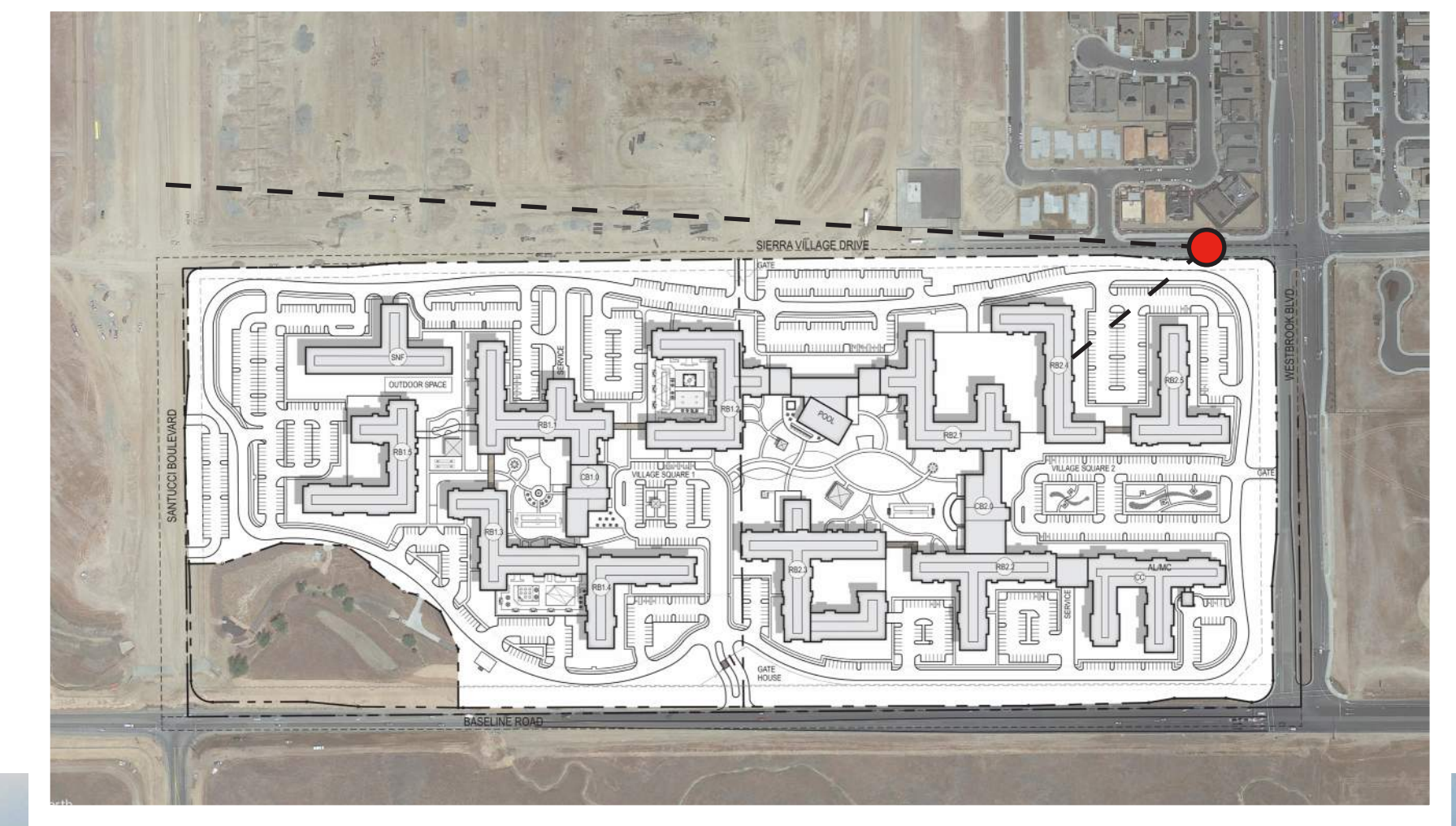







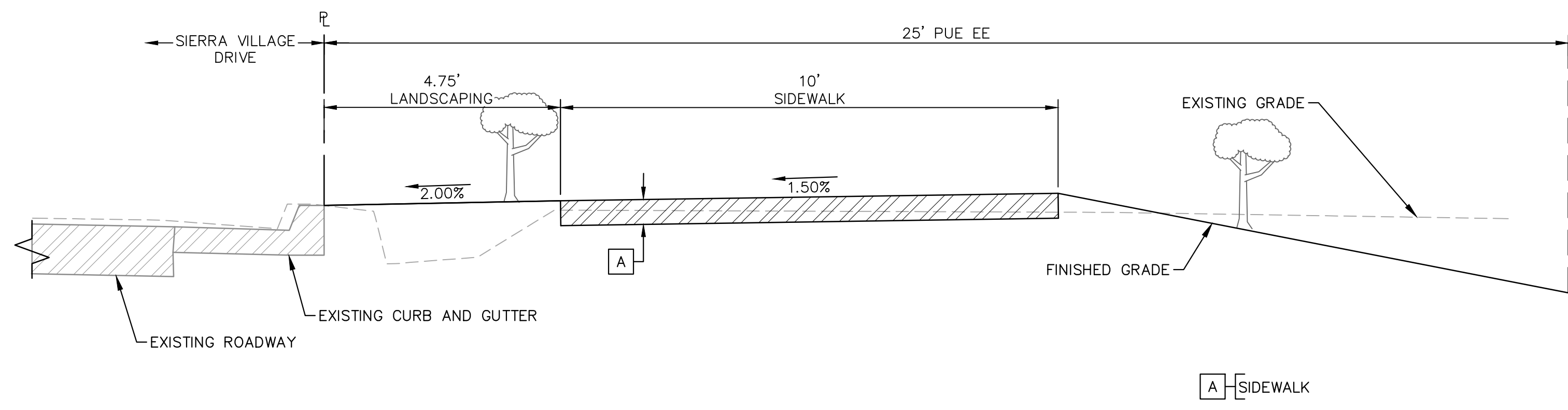

A SECTION THRU SIERRA VILLAGE DRIVE
NTS

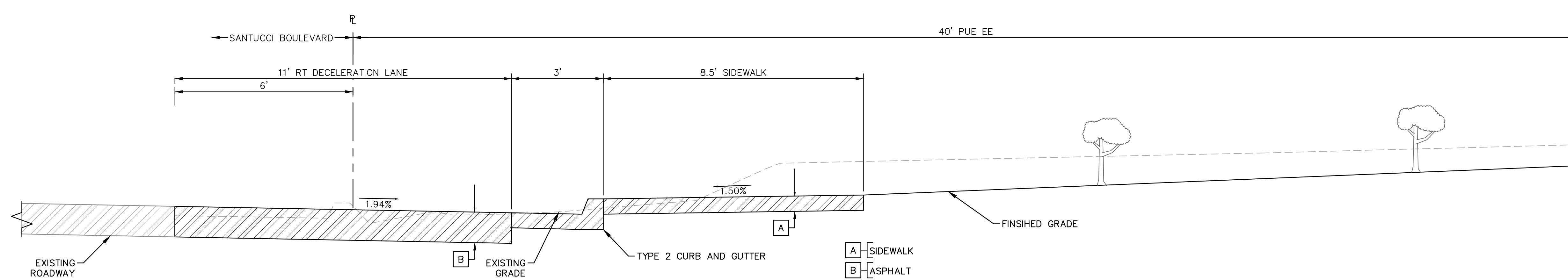

B SECTION THRU SANTUCCI BOULEVARD
NTS

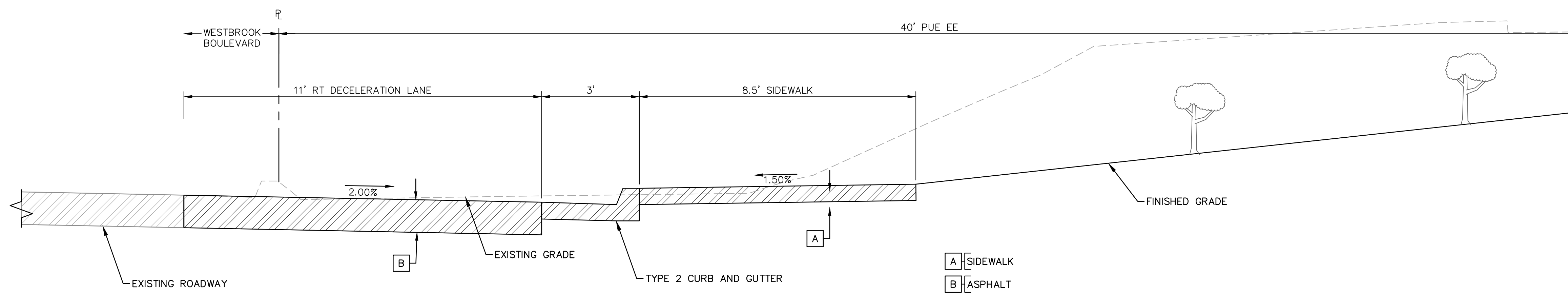

C SECTION THRU WESTBROOK BOULEVARD
NTS

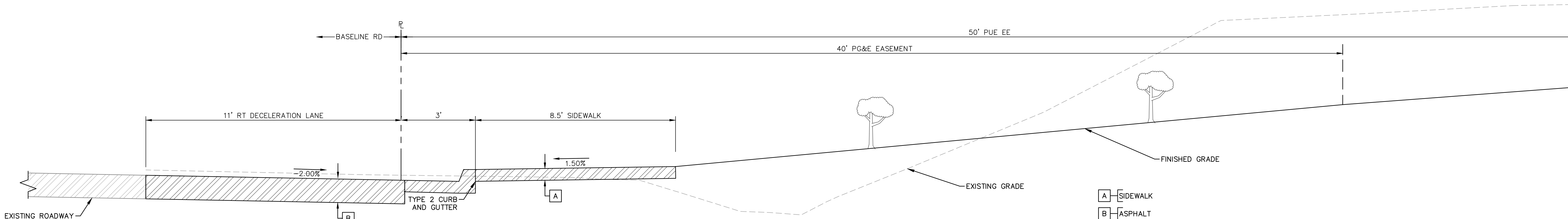

D SECTION THRU BASELINE ROAD
NTS

6000 BASELINE ROAD
ERICKSON SENIOR LIVING ROSEVILLE

MPP STAGE 1: SECTIONS

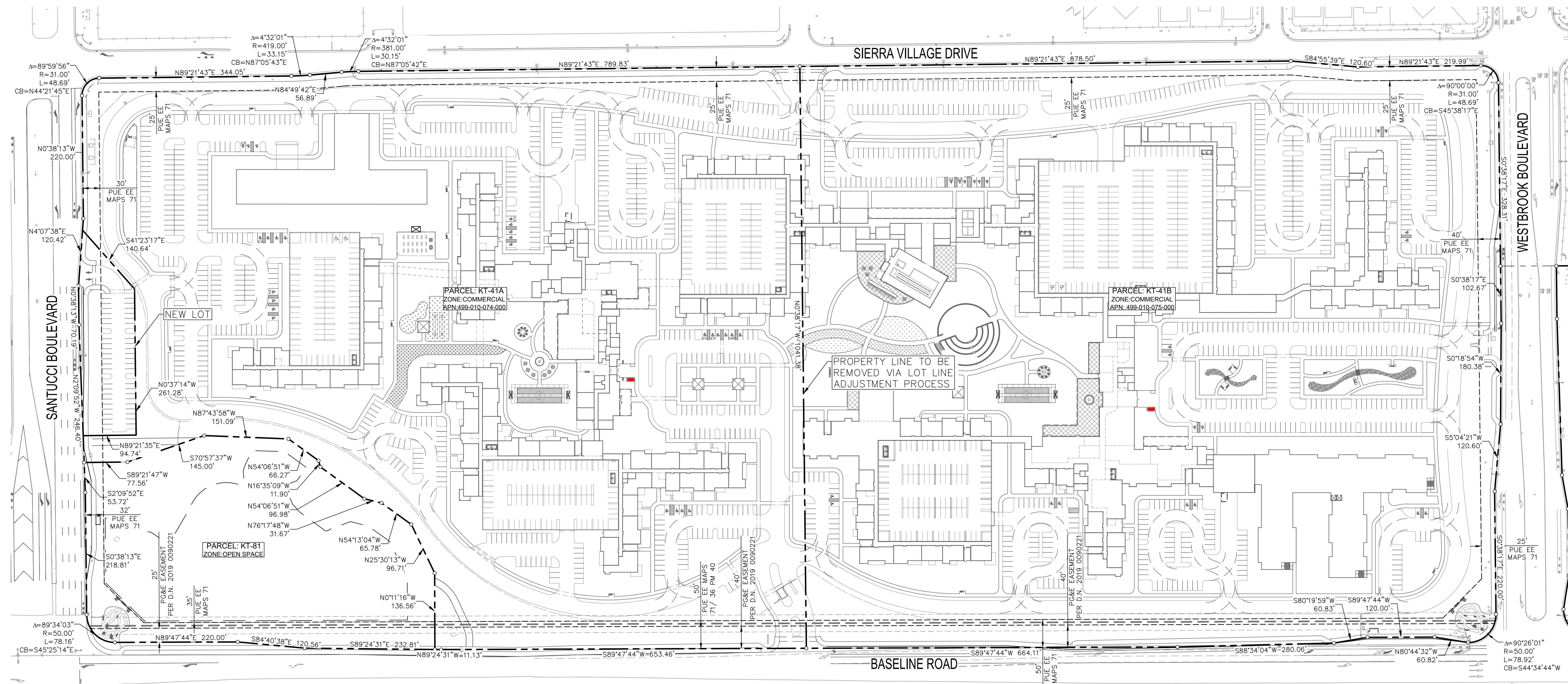
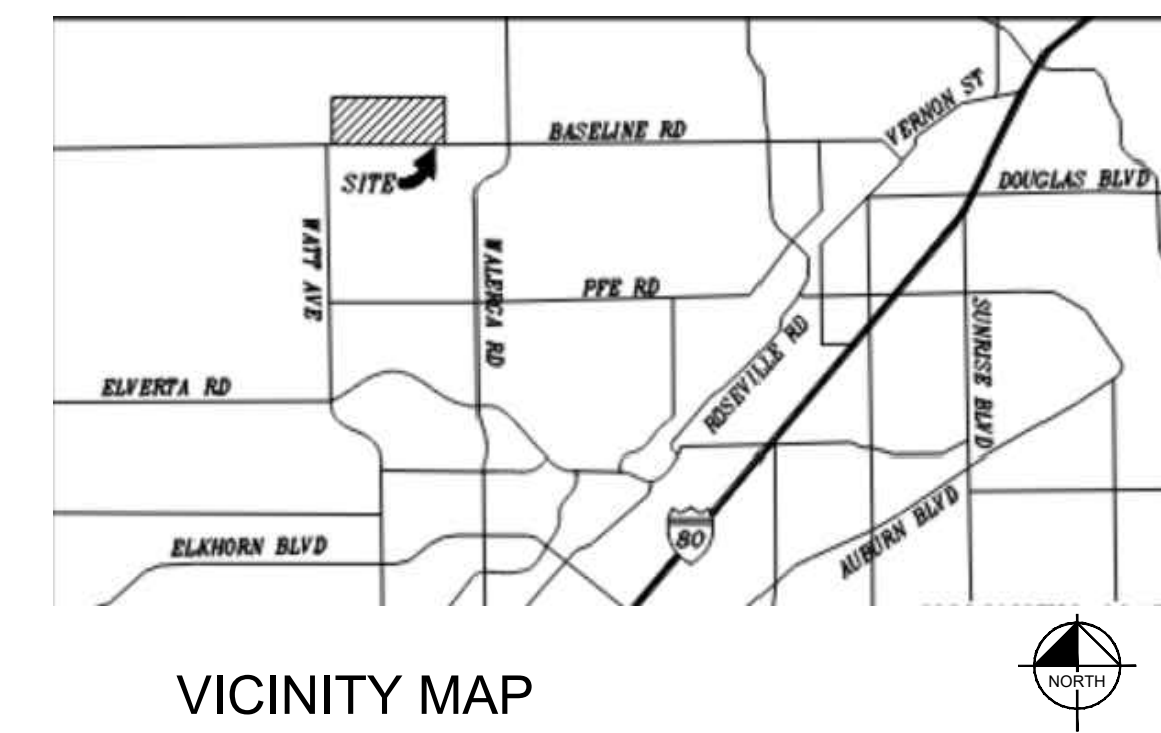

LEGEND

- PROPERTY LINE
- EASEMENT LINE

6000 BASELINE ROAD
ERICKSON SENIOR LIVING ROSEVILLE
LOT LINE ADJUSTMENT EXHIBIT

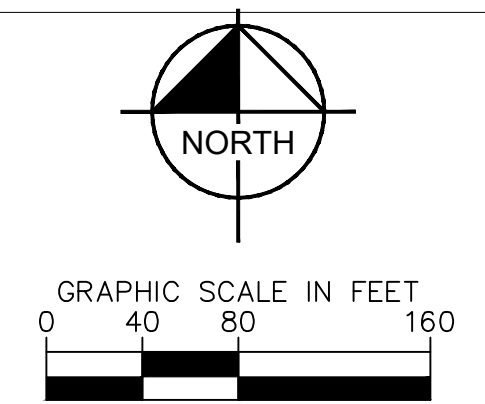

SIERRA VILLAGE DRIVE

SANTUCCI BOULEVARD

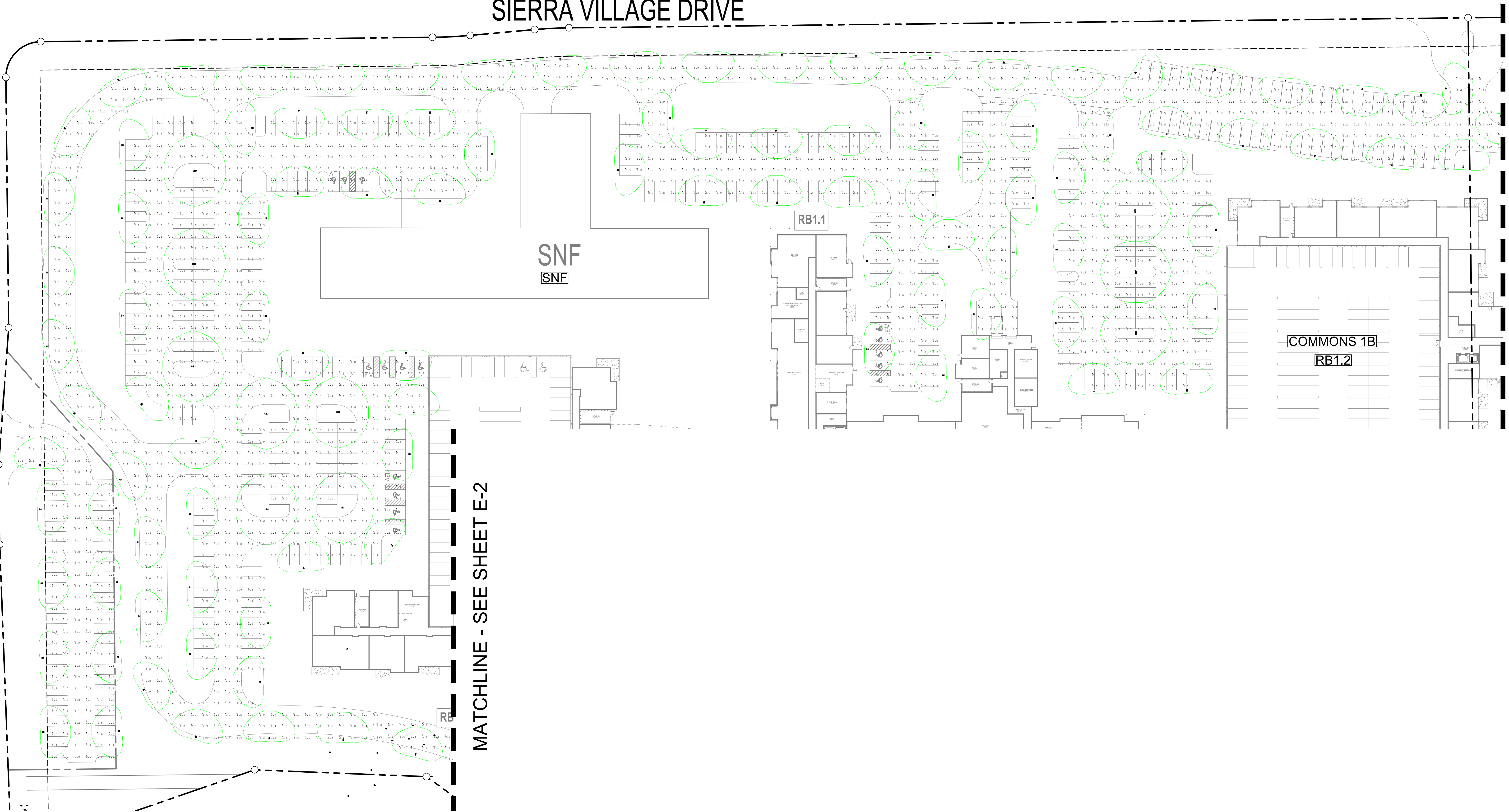

MATCHLINE - SEE SHEET E-3

MATCHLINE - SEE SHEET E-2

Calculation Summary

Label	CalcType	Units	Avg	Max	Min	Avg/Min	Max/Min
Park n Ride	Illuminance	Fc	1.44	2.5	0.7	2.06	3.57
Parking 1	Illuminance	Fc	1.37	2.8	0.7	1.96	4.00
Parking 2	Illuminance	Fc	1.57	2.9	0.8	1.96	3.63
Parking 3	Illuminance	Fc	1.44	2.6	0.7	2.06	3.71
Parking 4	Illuminance	Fc	1.68	3.0	0.7	2.40	4.29
Parking 5	Illuminance	Fc	1.47	2.8	0.7	2.10	4.00
Parking 6	Illuminance	Fc	1.42	2.6	0.7	2.03	3.71
Parking 7	Illuminance	Fc	1.52	2.8	0.7	2.17	4.00
Parking 8	Illuminance	Fc	1.56	2.9	0.7	2.23	4.14

Luminaire Schedule

Symbol	Qty	Label	Arrangement	Description	LLF	Luminaire Lumens
	22	37W LED_D	Back-Back	KH15QC1X37U4KC	0.920	4653
	319	37W LED	Single	KH15QC1X37U4KC	0.920	4653

6000 BASELINE ROAD
ERICKSON SENIOR LIVING ROSEVILLE

PHOTOMETRIC PLAN - E-1

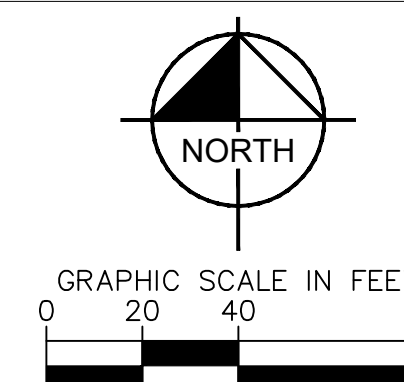

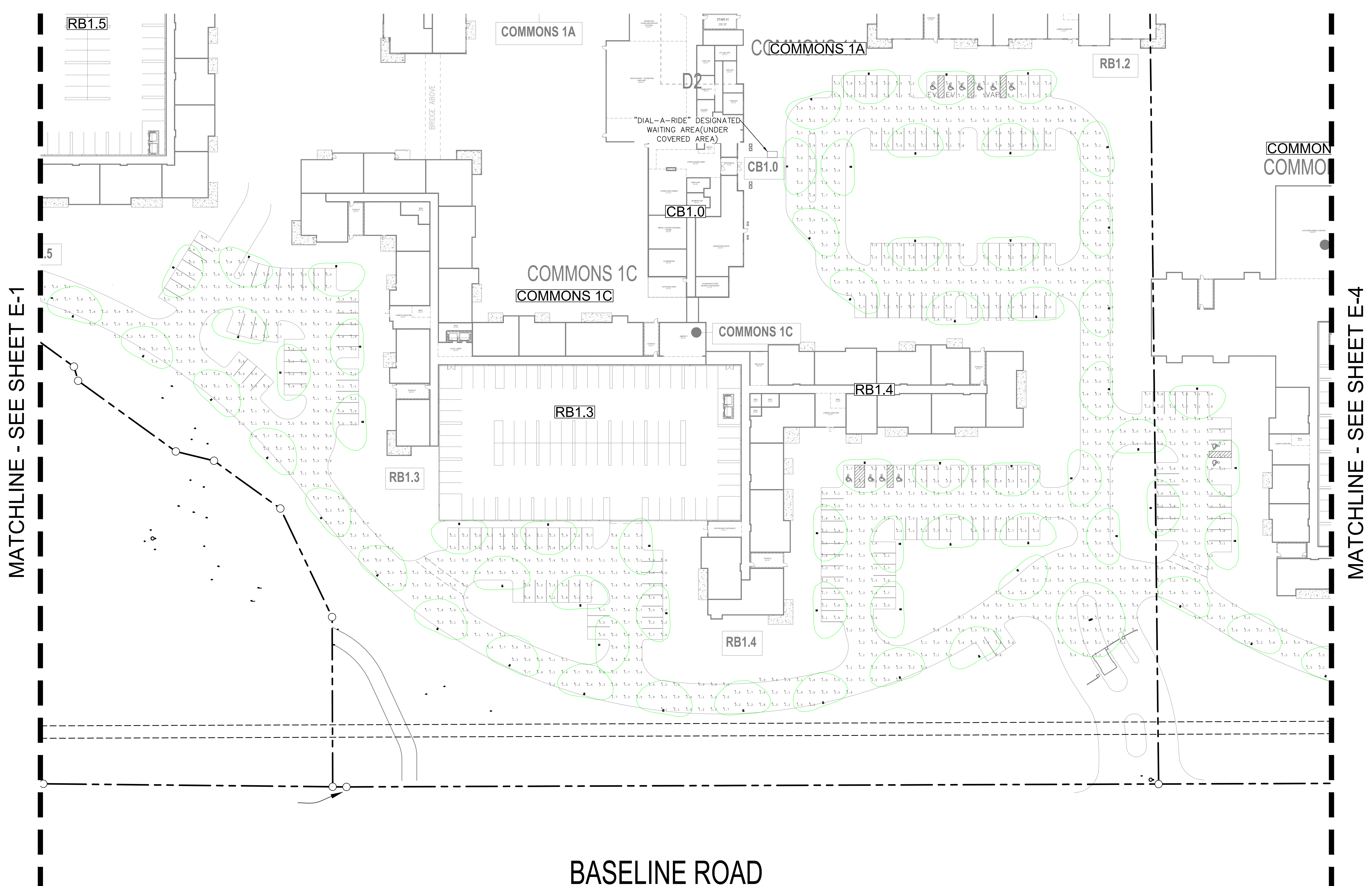

Calculation Summary							
Label	CalcType	Units	Avg	Max	Min	Avg/Min	Max/Min
Park n Ride	Illuminance	Fc	1.44	2.5	0.7	2.06	3.57
Parking 1	Illuminance	Fc	1.37	2.8	0.7	1.96	4.00
Parking 2	Illuminance	Fc	1.57	2.9	0.8	1.96	3.63
Parking 3	Illuminance	Fc	1.44	2.6	0.7	2.06	3.71
Parking 4	Illuminance	Fc	1.68	3.0	0.7	2.40	4.29
Parking 5	Illuminance	Fc	1.47	2.8	0.7	2.10	4.00
Parking 6	Illuminance	Fc	1.42	2.6	0.7	2.03	3.71
Parking 7	Illuminance	Fc	1.52	2.8	0.7	2.17	4.00
Parking 8	Illuminance	Fc	1.56	2.9	0.7	2.23	4.14

Luminaire Schedule						
Symbol	Qty	Label	Arrangement	Description	LLF	Luminaire Lumens
	22	37W LED_D	Back-Back	KH15QC1X37U4KC	0.920	4653
	319	37W LED	Single	KH15QC1X37U4KC	0.920	4653

6000 BASELINE ROAD
ERICKSON SENIOR LIVING ROSEVILLE

PHOTOMETRIC PLAN - E-2

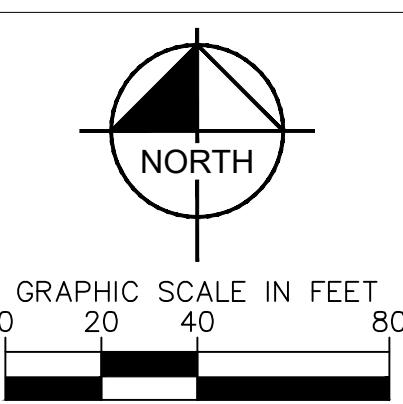

SIERRA VILLAGE DRIVE

MATCHLINE - SEE SHEET E-1

WESTBROOK BOULEVARD

MATCHLINE - SEE SHEET E-4

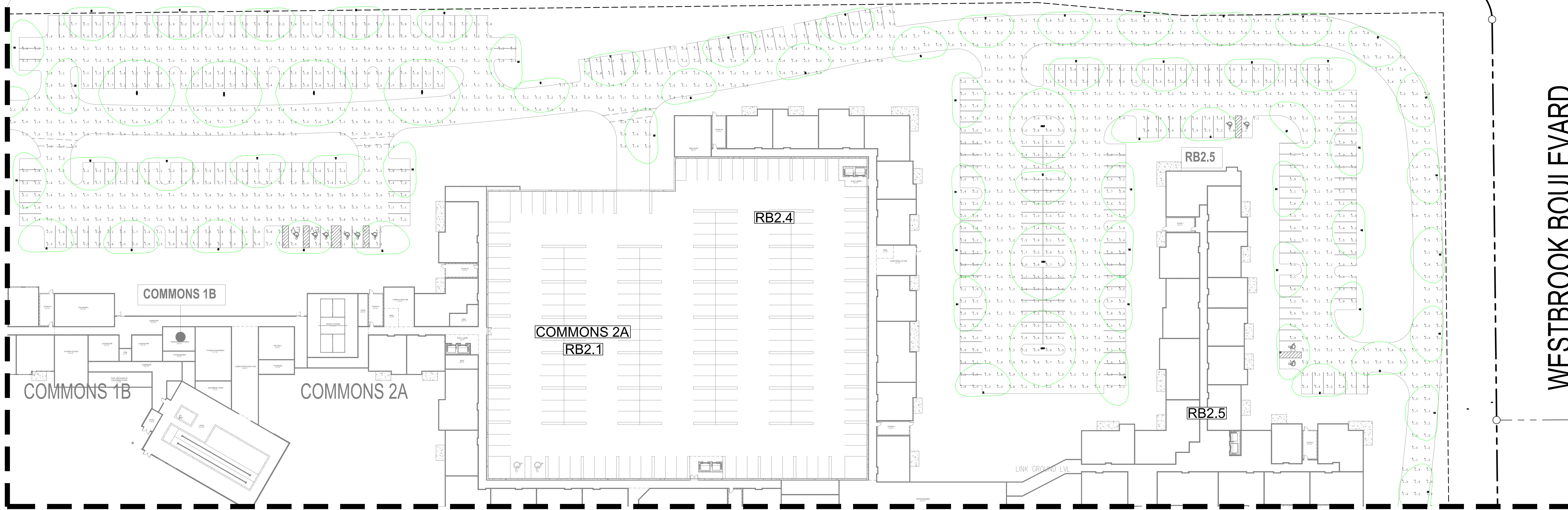

Calculation Summary

Label	CalcType	Units	Avg	Max	Min	Avg/Min	Max/Min
Park n Ride	Illuminance	Fc	1.44	2.5	0.7	2.06	3.57
Parking 1	Illuminance	Fc	1.37	2.8	0.7	1.96	4.00
Parking 2	Illuminance	Fc	1.57	2.9	0.8	1.96	3.63
Parking 3	Illuminance	Fc	1.44	2.6	0.7	2.06	3.71
Parking 4	Illuminance	Fc	1.68	3.0	0.7	2.40	4.29
Parking 5	Illuminance	Fc	1.47	2.8	0.7	2.10	4.00
Parking 6	Illuminance	Fc	1.42	2.6	0.7	2.03	3.71
Parking 7	Illuminance	Fc	1.52	2.8	0.7	2.17	4.00
Parking 8	Illuminance	Fc	1.56	2.9	0.7	2.23	4.14

Luminaire Schedule

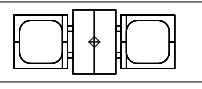
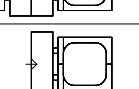
Symbol	Qty	Label	Arrangement	Description	L/LF	Luminaire Lumens
	22	37W LED D	Back-Back	KH15QC1X37U4KC	0.920	4653
	319	37W LED	Single	KH15QC1X37U4KC	0.920	4653

6000 BASELINE ROAD
ERICKSON SENIOR LIVING ROSEVILLE

PHOTOMETRIC PLAN - E-3

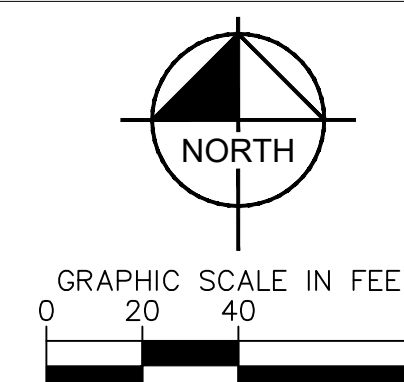

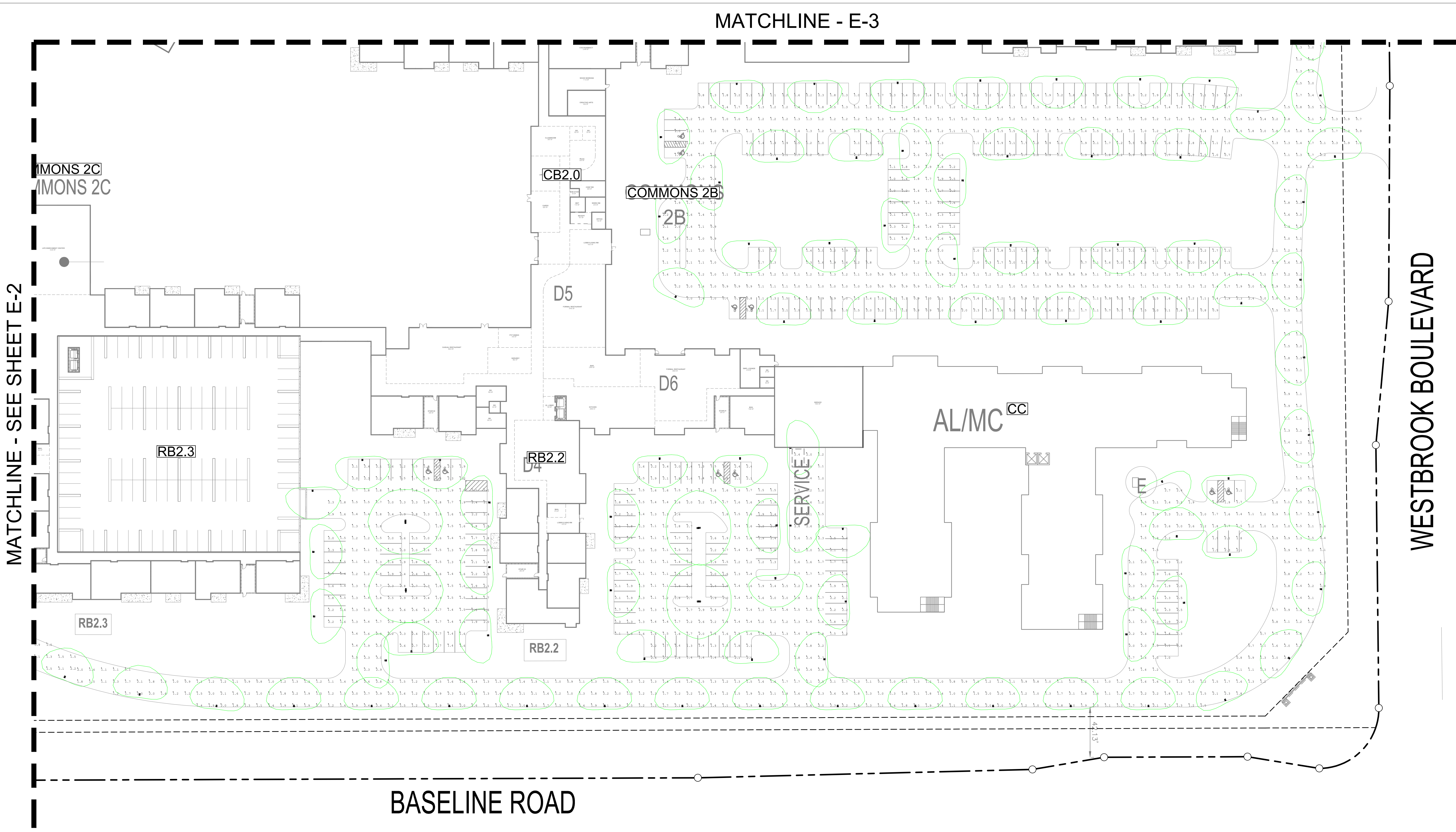

Calculation Summary

Label	CalcType	Units	Avg	Max	Min	Avg/Min	Max/Min
Park n Ride	Illuminance	Fc	1.44	2.5	0.7	2.06	3.57
Parking 1	Illuminance	Fc	1.37	2.8	0.7	1.96	4.00
Parking 2	Illuminance	Fc	1.57	2.9	0.8	1.96	3.63
Parking 3	Illuminance	Fc	1.44	2.6	0.7	2.06	3.71
Parking 4	Illuminance	Fc	1.68	3.0	0.7	2.40	4.29
Parking 5	Illuminance	Fc	1.47	2.8	0.7	2.10	4.00
Parking 6	Illuminance	Fc	1.42	2.6	0.7	2.03	3.71
Parking 7	Illuminance	Fc	1.52	2.8	0.7	2.17	4.00
Parking 8	Illuminance	Fc	1.56	2.9	0.7	2.23	4.14

Luminaire Schedule

Symbol	Qty	Label	Arrangement	Description	LLF	Luminaire Lumens
	22	37W LED_D	Back-Back	KH15QC1X37U4KC	0.920	4653
	319	37W LED	Single	KH15QC1X37U4KC	0.920	4653

6000 BASELINE ROAD
ERICKSON SENIOR LIVING ROSEVILLE

PHOTOMETRIC PLAN - E-4

